



DRIVE CONTROL POSITION

Specification

Revision: 1.0.0.5

Revision	Changes / Additions	Date
1.0.0.1	Implementation of a revision number; new Appendix „Character set of the comm. data channel“	2006-02-20
1.0.0.2	Chapter „Official DCP-Partners“ has been revised; manufacturer's code "VZ" (Venzke-DriveCon) has been implemented; description of the I7- and I9-messages has been revised	2006-12-20
1.0.0.3	The specification for saving error messages from the drive controller in chapter 5.11 was incorrect.	2007-03-05
1.0.0.4	Chapter „Official DCP-Partners“ has been revised; manufacturer's code "OS" (OSMA-Aufzüge) has been implemented;	2008-01-10
1.0.0.5	New Chapter „Fast Start Function“; The chapter "Definition of Messages" and Appendix "B Summary" were revised because of the fast start function; The chapter "Timeout Safety Function" was revised.	2008-09-10

Official DCP-Partners



BÖHNKE + PARTNER®
GMBH STEUERUNGSSYSTEME

BÖHNKE + PARTNER GmbH Steuerungssysteme
Industrieweg 13
51429 Bergisch Gladbach
Germany

Mr. Hendrik Bär h.baer@boehnkepartner.de
Mr. Jörg Hellmich j.hellmich@boehnkepartner.de



Brunner & Fecher Regelungstechnik GmbH
Bachgartenstraße 12
63743 Aschaffenburg
Germany

Mr. Wolfgang Brunner w.brunner@bf-regelungstechnik.de
Mr. Stephan Fecher s.fecher@bf-regelungstechnik.de



Control Techniques GmbH
Meystraße 20
53773 Hennef / Sieg
Germany

Mr. Dr.-Ing. Jürgen Fischer juergen.fischer@controltechniques.com
Mr. Dr. Holger König holger.koenig@controltechniques.com



Dietz-electronic GmbH Antriebstechnik
Max-Planck-Straße 15
72639 Neuffen
Germany

Mr. Götz Benczek benczek@dietz-electronic.de
Mr. Axel Wolfram wolfram@dietz-electronic.de



Fuji Electric FA Europe GmbH
Goethering 58
63067 Offenbach / Main
Germany

Mr. David Bedford dbedford@fujielectric.de



Kollmorgen Steuerungstechnik GmbH
Broichstraße 32
51109 Köln (Merheim)
Germany

Mr. Peter Gerstenmeyer pgerstenmeyer@kollmorgen.de
Mr. Franz Rudolf Kniel rkniel@kollmorgen.de

Official DCP-Partners (Continuation)



LiftEquip GmbH Elevator Components
Bernhäuser Straße 45
73765 Neuhausen a.d.F.
Germany

Mr. Walter Schäfer

walter.schaefer@liftequip.de



Magnetek (UK) Ltd.
20 Drakes Mews, Crownhill
Milton Keynes, MK8 OER. UK

Mr. Brian Preston

bpreston@magnetek.com



NEW LIFT Steuerungsbau GmbH
Lochhamer Schlag 8
82166 Gräfling
Germany

Mr. Simon Baker

simon.baker@newlift.de



OSMA-Aufzüge, Albert Schenk GmbH & Co KG
Hirtenstrasse Nr. 4
49084 Osnabrück
Germany

Mr. Klaus Hebbeler

hebbeler@osma-aufzuege.de



RST Elektronik GmbH
Tannenstraße 11
74229 Oedheim
Germany

Mr. Holger Betz

holger.betz@rst-elektronik.de



Schneider Steuerungstechnik GmbH
Gewerbstraße 7
83558 Maitenbeth
Germany

Mr. Anton Schneider

a.schneider@lisa-lift.de

Official DCP–Partners (Continuation)



STRACK LIFT AUTOMATION GmbH
Lieversfeld 8
42551 Velbert
Germany

Mr. Uwe Wagner

uwe.wagner@strack-lift-automation.de



Thyssen Krupp Aufzugswerke GmbH
Bernhäuser Straße 45
73765 Neuhausen
Germany

Mr. Olaf Breidenstein

olaf.breidenstein@thyssenkrupp.com



Vacon GmbH
Gladbecker Straße 425
45329 Essen
Germany

Mr. Bernd Roggenkamp

bernd.roggenkamp@vacon.de



Venzke-DriveCon GmbH
Zur Landwehr 25
48163 Münster
Germany

Mr. Olav Hennemann

hennemann@venzke.de

Mr. Martin Welp

welp@venzke.de



Ziehl-Abegg
Heinz-Ziehl-Straße
74653 Künzelsau
Germany

Mr. Gerhard Eisert

gerhard.eisert@ziehl-abegg.de

Mr. Hans-Jürgen Kuhn

hansjuergen.kuhnt@ziehl-abegg.de

Content

1	Introduction	9
2	Characteristics of DCP Interface	10
3	Master Messages from Lift Controller to Drive Controller	11
3.1	Command Byte	11
3.2	Data Bytes	13
3.3	Communications Bytes	13
3.4	Checksum Byte	13
3.5	Definition of Messages	14
3.5.1	Type of Messages at DCP3 Mode	14
3.5.2	Type of Messages at DCP4 Mode	15
3.5.3	Types of Command Modes	15
3.5.3.1	Idle Mode	15
3.5.3.2	Speed Mode	16
3.5.3.3	Speed Mode after a fast start	16
3.5.3.4	Stop Mode	16
3.5.3.5	Travel Mode	17
3.5.3.6	Deceleration Mode	17
3.5.3.7	Relevelling Mode (without Remaining Distance)	17
3.5.3.8	Remaining Distance Mode	17
4	Slave Messages from Drive Controller to Lift Controller	18
4.1	Status Byte	18
4.2	Data Bytes	20
4.2.1	Deceleration Distance	20
4.2.2	Extended Status	21
4.3	Communication Bytes	23
4.4	Checksum Byte	23
5	Communication Data Channel	23
5.1	General	23
5.2	Character Set	23
5.3	Data Transmission and Character Format	23
5.4	Data transmission Timeout-Control	24
5.5	Control Modes	24
5.6	Breakdown of Control Character Range (0 Hex to 1F Hex)	24
5.6.1	Characters common to remote Keypad and Display Control	24
5.6.2	Characters for remote Display Control of Lift Controller	25
5.6.3	Characters for remote Keypad Control of Lift Controller	25
5.6.4	Characters for Expanded Data Communications	25
5.7	Remote Display Control of Drive Controller (1F Hex)	26
5.8	Remote Keypad Control of Drive Controller (1F Hex)	26
5.9	Idle State	27

5.10	Synchronisation/Resetting of Communication Devices	27
5.11	Saving Error Messages from Drive Controller (1E Hex)	27
5.12	Expanded Data Communications between Lift- and Drive Controller (1C Hex).....	27
5.12.1	Expanded Data Transmission on Communication Channel (1C Hex)	27
5.12.2	Initialisation Message (,' ,0').....	28
5.12.2.1	Initialisation Message from Lift Controller	28
5.12.2.2	Initialisation Message from Drive Controller	28
5.12.2.3	Manufacturer Codes (alphabetic)	29
5.12.3	Mode Setting of the Data Bytes from the Drive Controller (,' ,1')	29
5.12.3.1	Mode Sequence from Lift Controller	29
5.12.3.2	Mode Sequence from Drive Controller	30
5.12.4	Start Parameter Message (,' ,7')	30
5.12.4.1	Start Parameter Message from Lift Controller	30
5.12.4.2	Response Parameter Message from Drive Controller	30
5.12.5	Position Message (,' ,9')	30
5.12.5.1	Position Message from Lift Controller	30
5.12.5.2	Response from Drive Controller	31
6	Behaviour in Event of Transmission Errors	31
6.1	Lift Controller	31
6.2	Drive Controller.....	31
7	Constrains	32
7.1	Interface.....	32
7.2	Timing.....	32
7.3	Timeout Safety Function.....	34
8	Definition of Travel Sequence	35
8.1	Nomenclature	35
8.2	Diagrams	35
9	Features Common to <i>DCP3</i> und <i>DCP4</i>.....	36
9.1	Notes on Command and Status Bits.....	36
9.1.1	Command Bit B0: Drive Controller Enable.....	36
9.1.2	Command Bit B4: Direction	36
9.1.3	Status Bit S0: Drive Controller Ready.....	36
9.1.4	Status Bit S1: Travel Activate Bit	37
9.1.5	Status Bit S2: Advance Warning.....	37
9.1.6	Status Bit S3: General Fault	37
9.1.7	Status Bit S6: Mechanical Brake.....	38
9.2	Travels Independent of <i>DCP3</i> and <i>DCP4</i>.....	38
9.2.1	Inspection Travel	38
9.2.1.1	Inspection Travel with V1.....	38
9.2.1.2	Inspection Travel with V0.....	39
9.2.2	Test Control Travel	39

9.2.3	Relevelling Travel none Depending on Remaining Distance.....	40
9.2.3.1	Relevelling Travel none Depending on Remaining Distance without <i>electric Stop</i>	40
9.2.3.2	Relevelling Travel none Depending on Remaining Distance with <i>electric Stop</i>	41
10	DCP3: Lift Controller without Absolute Sensor System.....	42
10.1	Travels at V4 followed by Constant Deceleration Distance SV4.....	42
10.1.1	Long Travel at high Lift Speed V4	42
10.1.2	Time Optimised short Travel at Lift Speed V4.....	43
10.2	Travels at intermediate speed V3, V2 and V1	43
10.2.1	Long Travel at intermediate speed	43
10.2.2	Time optimised short Travel at intermediate speed	44
10.3	Crawl Travel in DCP3.....	44
11	DCP4: Lift Controller with Absolute Sensor System	45
11.1	Time Optimised Direct Levelling Depending on Remaining Distance.....	45
11.1.1	Definition and Features of V4', V3' and VN' Travels.....	45
11.1.2	V4'-Travel	46
11.1.2.1	Exchange of Parameters between Lift Controller and Drive Controller before the Travel	47
11.1.3	V3'-Travel	49
11.1.4	VN'- Relevelling Travel Depending on Remaining Distance.....	50
11.2	Crawl Travel in DCP4.....	50
12	Fast Start Function	51
12.1	Starting sequence.....	51
12.1.1	Activation of the 'fast start function'	52
12.1.2	Actions and controls during 'fast start function'	52
12.1.3	Transition from 'fast start function' to normal travel	53
12.2	Premature termination of the 'fast start function'.....	53
12.2.1	Immediate termination regardless to the state of S6 'mechanical brake'.....	54
12.2.2	Premature termination considering the state of S6 'mechanical brake'	56
13	Appendix A: Character set of the communication data channel	58
14	Appendix B: Summary	59

1 Introduction

The Drive Control and Position (DCP) protocol is used for the serial link between a lift controller and drive controller, via an RS485 interface.

Its advantages over a conventional control link include:

- Simplified starting (adaptive, time optimised run depending on remaining distance determined online by the drive controller)
- Time optimised smooth direct levelling without crawl speed
- Adjustment accurate to the millimetre
- Drive controller external communication via lift controller and data communications

Since this protocol is used differently by the individual drive controller manufacturer, and various concepts arise depending on the CPU time available, the information content of the messages to be exchanged has been standardised for all manufacturer.

The DCP protocol distinguishes between two modes:

DCP3 (for lift controllers without absolute encoder system):

- Control via the serial DCP link instead of the terminal board.
- Status messages, such as fault and over temperature, are transmitted via the DCP link instead of by relay.
- Monitoring speed (such as relevelling-, deceleration- and over speed)

DCP4 (for lift controllers with absolute encoder system):

- As DCP3, plus:
- Time optimised direct levelling depending on remaining distance
- Millimetre accurate adjustment depending on distance
- Supervising the deceleration at the shaft ends

The description is separated into two parts. The chapters 2 to 7 are specifying the design and the usage of the DCP-protocol. The chapters 8 to 11 are describing the travel sequences using DCP3 and DCP4.

2 Characteristics of DCP Interface

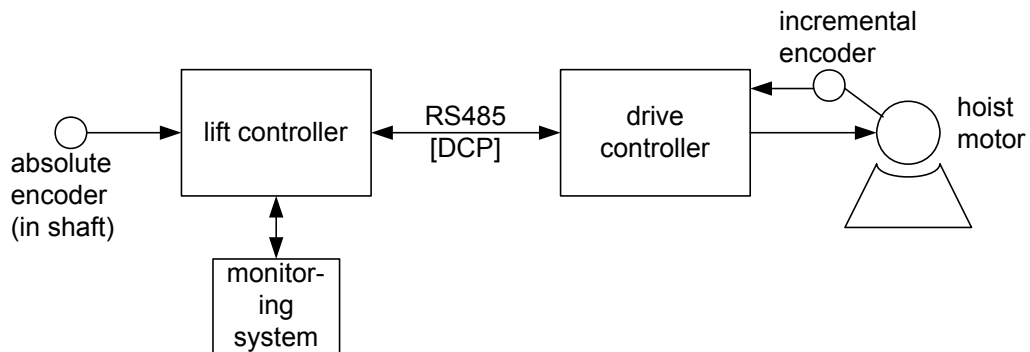

Figure 2-1: Connection via DCP

Physical:

- Point-to-Point link
- Driver controller and lift controller are linked via an RS485 interface (semi duplex mode)

Baud rate: 38.400 Baud

Data bits: 8

Parity: none

Stop bits: 1

Master / slave:

- The lift controller is the master
- The drive controller is the slave
- The messages are transferred in a 15ms cycle

Master messages from lift controller to drive controller:

Fixed length of 6 bytes.

1 st	2 nd -3 rd	4 th - 5 th	6 th
Command byte	Process data	Communication bytes	Checksum

Slave message from drive controller to lift controller:

Fixed length of 6 bytes.

1 st	2 nd -3 rd	4 th - 5 th	6 th
Status byte	Process data	Communication bytes	Checksum

Definition:

- **Time critical**, high speed **process** data (e.g. desired distance, switch-off points, travel command, etc.)
- **Non-time critical communication data** (e.g. display control, transfer of key codes, etc.)

No more than 2 bytes of communication data are transferred with each message, the remaining bytes being used for fast process data.

Data integrity:

- Each message is provided with a checksum byte

3 Master Messages from Lift Controller to Drive Controller

The message from the lift controller consists of 6 bytes and has the following format:

1 st	2 nd	3 rd	4 th	5 th	6 th
Command byte (B7.....B0)	Data byte 1	Data byte 2	Communicat. byte 1	Communicat. byte 2	Checksum

3.1 Command Byte

The first byte of the message is called the command byte. It contains the following information:

- Bit B0: Drive controller enable**
- Bit B1: Travel command (DCP3); Change of actual distance (DCP4)**
- Bit B2: Stop switch**
- Bit B3: Transfer of travel commands in the 3rd byte of message**
- Bit B4: Direction of travel**
- Bit B5: Speed change**
- Bit B6: Desired distance / actual distance**
- Bit B7: Error in last replay message**

B0: Drive controller enable
Information for the drive controller, that there will be an activation soon. This bit is set during a travel.
0: no activation of the drive (e.g. finish of travel or travel interruption)
1: drive activation during travel

B1: Travel command (DCP3); Change of actual distance (DCP4)
<u>DCP3:</u>
<ul style="list-style-type: none"> • The speed is set with the travel command • The drive controller is controlled in the usual way (like conventional wiring) • This bit is cleared at the deceleration point and the drive slows down.
<u>DCP4:</u>
<u>Remaining Distance Travel:</u>
<ul style="list-style-type: none"> • With a travel depending on distance, bit B1 is cleared, since the drive controller itself determines the optimum switch-off point (see chapter 3.5.3.8). • The speed transferred before the start of the travel is just a limit.
<u>Desired Distance Travel:</u>
With a travel of desired distance, bit B1 is set, the drive controller will receive the new desired distances from the lift controller.
Note: This function is not supported with the Kollmorgen lift controller program in DCP4-mode right now.

B2: Stop switch, V0 switch off
<u>DCP3:</u>
<ul style="list-style-type: none"> • The stop switch replaces terminal input v0. • The drive controller is controlled in the usual way.
<u>DCP4:</u>
<ul style="list-style-type: none"> • In this mode the lift controller signals that the drive controller is carrying out a travel depending on distance. • The stop switch is turned on from the start of the travel.
When the drive controller reaches the remaining distance of 0 mm, the mechanical brake is applied. The lift controller then turns the stop switch off.

B3: 1 => Transfer of travel commands in 3rd byte of message
This bit tells the drive controller that the following 2 bytes are being used to transfer a speed (see chapter 3.5.3.2). Byte 2 remains unused in this case (see also chapter 3.5.3.2).

B4: Direction of travel
This determines the direction of travel of the lift.
0: upwards
1: downwards

B5: Speed change
Note: This function is not supported with the Kollmorgen lift controller program at this time.
This bit signals a change in speed. The new speed must be notified in byte 3 in the same message.

B6: Desired distance / actual distance
Note: This function is not supported with the Kollmorgen lift controller program at this time.
This bit chooses the type of transmitted distance.
0: actual distance
1: desired distance

B7: Error in last reply message
This bit is set if the lift controller has detected a checksum error in the last message from the drive controller and has therefore ignored it.
In this situation the drive controller only repeats the communication byte.

3.2 Data Bytes

The content of the two data byte depends on the type of transmitted message (see chapter 3.5).

3.3 Communications Bytes

The exact significance and function of the communication bytes are described in chapter 5.

3.4 Checksum Byte

The checksum is the result of an XOR operation on all 5 data bytes. The resulting value must agree with that sent.

3.5 Definition of Messages

The following two tables show the valid messages of DCP3- and DCP4-Command mode and the meaning of the process information.

Nomenclature:

0: Bit is cleared 1: Bit is set x: Bit neither set nor cleared
 don't care: Drive controller is ignoring the value X: Value at range from 0 to 255

don't care: Ignore value

3.5.1 Type of Messages at DCP3 Mode

DCP3-Command mode						
Byte no.	Byte 1	Byte 2	Byte 3	Byte 4	Byte 5	Byte 6
Type of message	Command mode Bits 7 6 5 4 3 2 1 0	Process data		Communication bytes		CRC Check- sum
Idle mode	x 0 x x 0 0 0 0	don't care ⁽¹⁾	don't care ⁽¹⁾	X	X	X
Stop mode	x 0 x x 0 0 0 1	don't care	don't care	X	X	X
Relevelling mode	x 0 x x 0 0 1 1	don't care	don't care	X	X	X
Deceleration mode ^{*)}	x 0 x x 0 1 0 1	don't care	don't care	X	X	X
Travel mode	x 0 x x 0 1 1 1	don't care	don't care	X	X	X
Speed mode	x 0 x x 1 0 0 1	don't care ⁽¹⁾	speed	X	X	X
Speed mode after a fast start	x 0 x x 1 1 1 1	don't care ⁽¹⁾	speed	X	X	X

¹ In this case Kollmorgen lift controllers are sending the value 0x00

3.5.2 Type of Messages at DCP4 Mode

DCP4-Command mode						
Byte no.	Byte 1	Byte 2	Byte 3	Byte 4	Byte 5	Byte 6
Type of message	Command mode Bits 7 6 5 4 3 2 1 0	Process data		Communication bytes		CRC Check-sum
Idle mode	x 0 x x 0 0 0 0	don't care ⁽²⁾	don't care ⁽²⁾	X	X	X
Stop mode	x 0 x x 0 0 0 1	don't care	don't care	X	X	X
Relevelling mode	x 0 x x 0 0 1 1	don't care	don't care	X	X	X
Remaining distance mode ^{*)}	x 0 x x 0 1 0 1	remaining distance MSB	remaining distance LSB	X	X	X
Deceleration mode ^{*)}	x 0 x x 0 1 0 1	don't care	don't care	X	X	X
Travel mode	x 0 x x 0 1 1 1	don't care	don't care	X	X	X
Speed mode	x 0 x x 1 0 0 1	don't care ⁽²⁾	speed	X	X	X
Speed mode after a fast start	x 0 x x 1 1 0 1	don't care ⁽²⁾	speed	X	X	X

*) Note at message „x0xx0101“:

The next message after a speed mode message will decide how a „x0xx0101“-message must to be process:

If, after a speed mode message, a travel mode message will follow, then all occurrences of „x0xx0101“ messages will processes as deceleration mode messages.

If, after a speed mode message, a „x0xx0101“ message will follow, then that and all other messages will be process as remaining distance mode messages.

3.5.3 Types of Command Modes

It follows a description of each command mode message and their broadcast time.

3.5.3.1 Idle Mode

Available: DCP3 and DCP4

Time: Idle state

Contents: none

² In this case Kollmorgen lift controllers are sending the value 0x00

3.5.3.2 Speed Mode

Available:	DCP3 and DCP4	
Time:	Once before start of travel	
Contents:	<u>permissible speed:</u>	
	Bit	DCP notation speed name
	G0	V0 crawl
	G1	VN relevelling
	G2	VF fast start
	G3	V1 intermediate 3
	G4	V1 inspection
	G5	V2 intermediate 2
	G6	V3 intermediate 1
	G7	V4 fast

Speed modes V2 and V1 are not available under DCP4.

Under DCP3 the usages of the speed modes from V2 and V1 are depending on the demanded speeds for the specific lift installation. Due to compatibility to former versions the modes are assigned in the following way:

Installation with one travelling speed:	V4	
Installation with two travelling speeds:	V4, V3	with $V4 > V3$
Installation with three travelling speeds:	V4, V3, V2	with $V4 > V3 > V2$
Installation with four travelling speeds:	V4, V3, V2, V1	with $V4 > V3 > V2 > V1$

3.5.3.3 Speed Mode after a fast start

Available:	DCP3 and DCP4	
Time:	After the doors are closed when starting a travel with the speed mode VF (fast start).	
Contents:	<u>permissible speed:</u> (see chapter 3.5.3.2 with the exception of the speeds VN and VF)	

3.5.3.4 Stop Mode

Available:	DCP3 and DCP4	
Time:	During deceleration (waiting until the „Stop“ message from drive controller)	
Contents:	none	

3.5.3.5 Travel Mode

Available: DCP3 and DCP4

Time: During travel

Contents: none

Note: Travel mode messages, while DCP4 mode is active, will only be used for none remaining distance travel, like inspection-, test control- and learning travel.

3.5.3.6 Deceleration Mode

Available: DCP3 and DCP4

Time: During deceleration

Contents: none

Note: Deceleration mode messages, while DCP4 mode is active, will only be used for none remaining distance travel, like inspection-, test control- and learning travel.

3.5.3.7 Relevelling Mode (without Remaining Distance)

Available: DCP3 and DCP 4

Time: Only used during relevelling mode without remaining distance.

Contents: none

Note: This mode is only for special use (e.g. with pawl devices) on DCP4 mode and haven't relevelling with remaining distance.

3.5.3.8 Remaining Distance Mode

Available: DCP4

Time: From start of travel until the lift car comes to the level

Contents: Absolute remaining distance [mm] up to level.

Note: Remaining distance messages will be used in DCP4 mode for remaining distance travel.

The bit B1 from command byte must be cleared!

The remaining distance is a positive value until the destination level has been reached. After overdriven a destination level the remaining distance will be set to 0.

If the remaining distance will be greater than 7FFF (Hex), it will bordered to 7FFF (Hex)!

4 Slave Messages from Drive Controller to Lift Controller

The reply message from the drive controller consists of 6 bytes and has the following format:

1 st	2 nd	3 rd	4 th	5 th	6 th
Status byte (S7....S0)	Data byte 1	Data byte 2	Communicate. byte 1	Communicate. byte 2	Checksum

4.1 Status Byte

The status byte contains the following information:

Bit S0: Drive controller ready

Bit S1: Travel active

Bit S2: Advance warning active

Bit S3: General fault active

Bit S4: Motor speed below levelling value ($v < 0,3$ m/s)

Bit S5: Desired distance / speed accepted (bit cleared for emergency stop)

Bit S6: Mechanical brake

Bit S7: Error in last message received

S0: Drive controller ready
The drive controller is ready for the next run. This status bit is similar to the terminal "Drive controller ready" at the lift controller.
0: Drive controller is not ready to travel
1: Drive controller is ready to travel

S1: Travel active
The drive controller is currently carrying out a run.
0: Not in travel
1: In travel

S2: Advance warning active

Plausible causes for activating an advance warning is generally at the responsibility of the drive manufacturer. The following causes could be possible:

- The temperature of the heat sink is less than 10°C away from the cut out threshold of 70°C.

The travel can be continued to the next floor. The lift controller should then not give any more travel commands while this advance warning remains activated.

S3: General fault active

The drive controller timeout monitoring error message is set. The drive controlled has been switched off, the run contactor opened and the brake applied. Possible causes of the fault include:

- Tachometer polarity wrong
- Will not start or no tachometer signal
- Over speed
- Over current
- Over voltage in intermediate circuit
- Under voltage in intermediate circuit
- Motor parameter mismatch
- Power section over temperature
- Processor failure

The command „Drive controller enable“ (see command bit B0) must be cleared at this situation! The lift controller will not travel until the status „General fault active“ has been deactivated by the drive controller.

S4: Motor speed below levelling value ($v < 0,3$ m/s)

The motor speed has dropped to or below the levelling value. This signal will be used for monitoring the releveling speed ($v < 0,3$ m/s) by the lift controller.

0: $v \geq 0,3$ m/s

1: $v < 0,3$ m/s

S5: Desired distance / speed accepted

The desired distance resp. speed was accepted by the drive controller.

Note: If a plausibility error is found in the remaining distance transmitted, the drive controller should carry out an emergency stop. This bit is then cleared until the lift has stopped.

The drive controller should then output a error message.

Note: This function is not analysed by the Kollmorgen lift controller program at this time.

S6: Mechanical brake
Corresponds to the mechanical break relay (MB relay) of the drive controller.
0: mechanical break active / applied
1: mechanical break not active / opened

S7: Error in last message received
This bit is set if the drive controller has detected a checksum error in the last message from the lift controller and has therefore ignored it.
In this situation the lift controller only repeats the communication byte.

4.2 Data Bytes

At the two data bytes there will be alternating the values of the deceleration distance and the extended status information. These values must be handle careful, because each type of transmitted information should be updated only every 30 ms.

Depending at the most significant bit (bit 15), the meaning should be like in the following table is shown:

Data Byte 1		Data Byte 2
Bit 15	Bit 8 – 14	Bit 0 – 7
0	Deceleration distance	
1	Extended Status	

With a setting via the communication channel it is possible to switch off the alternating message information and choose only the deceleration distance or the extended status.

4.2.1 Deceleration Distance

Note: This function is not analysed by the Kollmorgen lift controller program at this time.

Data Byte 1 deceleration Distance MSB		Data Byte 2 Deceleration Distance LSB
Bit 15	Bit 8 – 14	Bit 0 – 7
0	Deceleration Distance MSB	Deceleration Distance LSB

Bit 0 - 7: Deceleration Distance LSB (least significant bit)

Bit 8 - 14: Deceleration Distance MSB (most significant bit)

Bit 15: Mode Identification (0 = Data of deceleration distance)

The maximum deceleration distance is be bordered up to 7FFF (Hex), this is similar to 32,767 m.

While lift is stationary or just starting the value for the deceleration distance will be at 7FFF (Hex). During acceleration the value will be incremented up from 0 (Hex). After reaching a constant speed and during the deceleration time the deceleration distance will be stay constant.

Bit 15: Mode Identification
The deceleration distance will be only available if the mode identification is cleared.

4.2.2 Extended Status

The extended status information are areas with different meanings, that will be generated by the drive controller.

Data Byte 1 Extended Status								Data Byte 2 Extended Status							
15	14	13	12	11	10	9	8	7	6	5	4	3	2	1	0
Mode	Not used				Emergency Power		Weight Monitoring					Speed Monitoring			
1	-	-	-	-	Recom. Dir.	Interm. Circuit	res	res	res	res	res	res	V _{Über}	V _{Grenz}	V _{Einf}

Bit 0: V_{Einf} Speed for Unlocking Zone

Bit 1: V_{Grenz} Border Speed

Bit 2: V_{Über} Over speed

Bit 3: Reserved

Bit 4 - 8: Reserved for Weight Detection

Bit 9: Emergency Power: Reduced voltage in intermediate circuit (accumulator)

Bit 10: Emergency Power: Recommended Travel Direction

Bit 11 - 14: not used

Bit 15: Mode Identification (1 = Status Data)

Bit 0: V_{Einf} Speed for Unlocking Zone
The actual speed is slower than the maximum speed for unlocking zone ($v < 0,8$ m/s).
0: The actual speed is faster or equal than the max. speed for unlocking zone ($v \geq 0,8$ m/s)
1: The actual speed is slower than the max. speed for unlocking zone ($v < 0,8$ m/s)

Bit 1: V_{Grenz} Border Speed
The actual speed is slower than the adjustable border speed. 0: The actual speed is faster or equal than the border speed ($v \geq v_{Grenz}$) 1: The actual speed is slower than the border speed ($v < v_{Grenz}$)
Bit 2: $V_{Über}$ Over speed
The actual speed is slower than the adjustable over speed. 0: The actual speed is faster or equal than the over speed ($v \geq v_{Über}$) 1: The actual speed is slower than the over speed ($v < v_{Über}$).
Bit 3: Reserved
At this time not supported!
Bit 4-8: Reserved for Weight Detection
These bits are reserved for weight detection. At this time not supported.
Bit 9: Emergency Power: Reduced voltage in intermediate circuit (accumulator)
The drive controller has reduced voltage (accumulator) during emergency power. Furthermore travelling will be started only with reduced speed. 0: reduced voltage in intermediate circuit not active 1: reduced voltage in intermediate circuit active
Bit 10: Emergency Power: Recommended Travel Direction
The drive controller recommend the travel direction during emergency power for the next travel. 0: upwards (The counterweight is much more heavy than the lift car) 1: downwards (The lift car is much more heavy than the counterweight)
Bit 11-14: not used

Bit 15: Mode Identification
The extended status information will be only available if the mode identification is set.

4.3 Communication Bytes

The exact significance and function of the communication bytes are described in chapter 5 .

4.4 Checksum Byte

The checksum is the result of an XOR operation on all 5 data bytes. The resulting value must agree with that sent.

5 Communication Data Channel

5.1 General

The communication data channel is subordinate to the real time channel and is operated with its own protocol.

It allows:

- Access to all drive controller desired values and parameters
- Remote control using the keypad and display of the lift controller
- External remote control using the lift controller and data communication system
- The exchange of additional data between lift controller and drive controller

5.2 Character Set

An ASCII protocol is used.

- The transmit characters are limited to the ASCII character set from 20 (Hex) to FF (Hex).
- The remaining 32 characters are available for control purposes (0 Hex to 19 Hex).

This offers advantages, especially for remote diagnostics, since an ASCII protocol is extremely easily integrated into a standardised data frame.

5.3 Data Transmission and Character Format

Since only the ASCII characters from 20 (Hex) to FF (Hex) are available for data transmission, it must be insured that no character outside this range arise within the data bytes, since this would result in malfunctions. An effective method of avoiding such problems is to convert the data bytes into ASCII format in order to ensure they lie outside the range of control characters. This method offers the bonus of an additional plausibility check to pick up transmission errors not detected by calculating the checksum (e.g. 2 bits falsified). The transmitted data is encapsulated into a data frame.

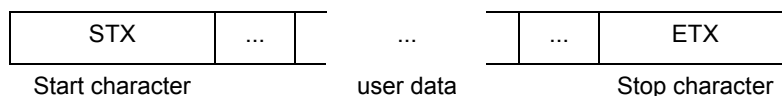

5.4 Data transmission Timeout-Control

If messages are not exchanged within one second, the communication devices at both ends are automatically reset to their initial state.

If there is no “ETX” character received within one second after a “STX” character was received, the communication data channel is also reset to its initial state.

5.5 Control Modes

Operation of the communication channel can be broken down into the following modes:

- Remote display control via the lift controller
- Remote keypad control via the lift controller
- Expanded data communication between lift controller and drive controller
- Idle state

Note:

The whole ability to operate the drive controller is possible during the remote operation. Display lines will be transmitted and shown at stopping as well as in travel. After changing a parameter at the drive controller via the remote operation, the *drive controller ready bit S0* must switch off and no further travel command need to be accepted.

After leaving the remote operation without any modifications the drive controller switch on the *drive controller ready bit S0* and is ready to travel.

5.6 Breakdown of Control Character Range (0 Hex to 1F Hex)

5.6.1 Characters common to remote Keypad and Display Control

Communications idle:

00 Hex	Communications idle
--------	---------------------

Message identification:

02 Hex	STX (start of text)
--------	---------------------

03 Hex	ETX (end of text)
--------	-------------------

Control mode:

1C Hex	expanded data communications
--------	------------------------------

1D Hex	not used
--------	----------

1E Hex	Displaying and saving error messages from the drive controller in lift controllers event memory
--------	---

1F Hex	Remote control, signalling for both communication devices
--------	---

5.6.2 Characters for remote Display Control of Lift Controller

Line number (Number of lines depends on lift and drive controller):

04 Hex	Output in line 1
05 Hex	Output in line 2
06 Hex	Output in line 3
07 Hex	Output in line 4

Cursor position (Number of cursor positions depends on lift and drive controller):

08 Hex	Cursor position 0
09 Hex	Cursor position 1
	to
1A Hex	Cursor position 18
1B Hex	Cursor position 19

5.6.3 Characters for remote Keypad Control of Lift Controller

(depending on drive controller)

The number of keys and the meaning of the keypad are depending at the drive controller!

00 Hex	No button pressed	(0000.0000 bin = 00 Hex)
04 Hex	button "1"	(0000.0100 bin = 04 Hex)
08 Hex	button "2"	(0000.1000 bin = 08 Hex)
10 Hex	button "3"	(0001.0000 bin = 10 Hex)
20 Hex	button "4"	(0010.0000 bin = 20 Hex)
40 Hex	button "5"	(0100.0000 bin = 40 Hex)

Each button is assigned to one bit. This also allows transmissions of the fact that two buttons have been pressed simultaneously.

5.6.4 Characters for Expanded Data Communications

1st character:

49 Hex	,l' character	Internal command
--------	---------------	------------------

2nd character:

30 Hex	,0' character	Manufacturer's identification
31 Hex	,1' character	Setting for data byte 2 and 3
37 Hex	,7' character	Travel distance parameter
39 Hex	,9' character	Actual position

5.7 Remote Display Control of Drive Controller (1F Hex)

In this mode the display of the lift controller is used for outputting the drive controller's menu texts.

Switching to this mode is initiated with the character string (STX) (1F Hex) and ended with an (ETX) character.

Immediately the lift controller recognized a display control character (line, cursor position), the subsequently transmitted characters are output in the required position.

Example 1: Displaying a complete display line

STX	1F	line	cursor position	character 1	character n	ETX
-----	----	------	-----------------	-------------	-------	-------------	-----

n = 1..20

Example 2: Displaying several characters at different positions⁽³⁾

STX	1F	line	cursor position	character 1	line	cursor position	character 2	ETX
-----	----	------	-----------------	-------------	------	-----------------	-------------	-------	-----

See chapter 5.6.2 for definition of characters.

If another (STX) character is sent before an output data stream is ended, the complete display unit has to be cleared (e.g. in the case of intermittent interruption of communication) and the transmission restarts.

5.8 Remote Keypad Control of Drive Controller (1F Hex)

In this mode the keypad of the lift controller is used to pass user input to the drive controller.

Switching to this mode is initiated with the character string (STX) (1F) and ended with an (ETX) character.

A keystroke transfer has the following format:

STX	1F	button	ETX
-----	----	--------	-----

See chapter 5.6.3 for definition of characters!

³ It's possible to transmit the total content of the display within one data package. Anyhow it's advised not to do so, because the refresh rate of the display decreases this way (e. g. when transmitting four lines with 20 characters each, the display will be only refreshed two times in a second). In that case a line orientated transmission such as shown in Example 1 is preferable.

The number of characters, that can be displayed at the same time, depends on the lift controllers hardware (number of columns and lines of the display).

5.9 Idle State

If data is not being communicated on the channel, null bytes are transferred (00 Hex), i.e. communication are idle.

00

5.10 Synchronisation/Resetting of Communication Devices

The communication device can be reset to its initial state (display cleared) at any time with the character string (STX)(ETX) (generally recommended before switching control mode).

STX	ETX
-----	-----

5.11 Saving Error Messages from Drive Controller (1E Hex)

For the drive controller it is possible to intervene asynchronously in an ongoing exchange of messages at any time, in order to display drive controller error messages on the lift controller display and to save it to the lift controllers event log⁽⁴⁾.

If a message is just started to transmit, the drive controller should first complete this message before the error message would be started. With this procedure it's the best way to prevent losing data.

Switching to this mode is initiated with the character string (STX) (1E Hex) and ended with an (ETX) character.

An error message output therefore has the following format:

STX	1E	character	character	character	ETX
		1	2		n	

n = 1..20

5.12 Expanded Data Communications between Lift- and Drive Controller (1C Hex)

In this mode additional data can be exchanged between lift controller and drive controller.

Switching to this mode is initiated with the character string (STX) (1C Hex) and ended with an (ETX) character.

See chapter 5.6.4 for definition of characters!

5.12.1 Expanded Data Transmission on Communication Channel (1C Hex)

The messages defined by the date of publication of this document are described below.

The lift controller always initiates communication. The drive controller only responds.

⁴ Error messages will be saved in the controllers event log. With the error time stamp the user will have a good opportunity to check and detect errors and synchronize with error messages from the lift controller. A further check of the error message won't be made by the lift controller.

5.12.2 Initialisation Message (,'0')

The lift controller and the drive controller start the communication with the following initialisation messages. After that both controller could check and adjust their settings.

The drive controller receive the language settings from the lift controller and switch to the same language. Didn't the drive controller support the received language setting, it need to switch to English speech as a default setting.

Did the drive controller receive none or faulty initialisation messages from the lift controller, it mustn't activate a travel sequence. The drive controller could generate an event message and after that it stops the communication for only few seconds. A timeout situation will occurs and the lift controller starts the initialisation sequence again.

5.12.2.1 Initialisation Message from Lift Controller

The lift controller sends inquiry after switching on / reset and disconnection (timeout).

STX	1C	,	'	,	0'	HK1	HK2	V10.0	V1.0	V0.1	V0.01	D	D	M	M	Y	Y	LK1	LK2	ETX
-----	----	---	---	---	----	-----	-----	-------	------	------	-------	---	---	---	---	---	---	-----	-----	-----

HKx Lift controller manufacturer's identification

Vx Version number (tens, ones, tenths and hundredths place)

DDMMYY Date of software

LKx Country identifier at ISO 639 in capital letters (e.g. DE for Germany)

5.12.2.2 Initialisation Message from Drive Controller

Response message from the drive controller after receiving lift controller's message.

STX	1C	,	'	,	0'	HK1	HK2	V10.0	V1.0	V0.1	V0.01	D	D	M	M	Y	Y	DCP	LK1	LK2	ETX
-----	----	---	---	---	----	-----	-----	-------	------	------	-------	---	---	---	---	---	---	-----	-----	-----	-----

HKx Drive controller manufacturer's identification

Vx Version number (tens, ones, tenths and hundredths place)

DDMMYY Date of software

DCP Type of DCP (,'3' = DCP3, ,'4' = DCP4)

LKx Country identifier at ISO 639 in capital letters (e.g. DE for Germany)

5.12.2.3 Manufacturer Codes (alphabetic)

<i>Lift controller manufacturer's</i>	<i>Identifi- cation</i>	<i>Drive controller manufacturer's</i>	<i>Identifi- cation</i>
Böhnke + Partner GmbH	BP	Brunner & Fecher Regelungstechnik GbR	BF
Kollmorgen Steuerungstechnik GmbH	KN	Control Techniques GmbH	CT
NEW LIFT Steuerungsbau GmbH	NL	Dietz-electronic GmbH	DE
OSMA-Aufzüge, Albert Schenk GmbH & Co KG	OS	Fuji Electric GmbH	FE
Schneider Steuerungstechnik GmbH		MagneTek (UK) Ltd.	MT
Strack Lift Automation GmbH	ST	RST Elektronik GmbH	RS
		Thyssen Krupp Aufzugswerke GmbH	TY
		Venzke-DriveCon GmbH	VZ
		Ziehl-Abegg AG	ZA

5.12.3 Mode Setting of the Data Bytes from the Drive Controller (,I', ,1')

The two data bytes transmit alternate the deceleration distance and extended status information. This mode could be changed by transmitting the following message during the initialisation sequence.

5.12.3.1 Mode Sequence from Lift Controller

The lift controller could set up the kind of information at the data bytes while transmitting a message during the initialisation sequence to the drive controller:

STX	1C	,I'	,1'	Reserved	information	ETX
-----	----	-----	-----	----------	-------------	-----

reserved ,0' not used and reserved for further features

Information ,0' = alternating deceleration distance and extended status (default setting)

 ,1' = always deceleration distance

 ,2' = always extended status

5.12.3.2 Mode Sequence from Drive Controller

Response message from the drive controller after receiving lift controller's message:

STX	1C	,l'	,1'	ETX
-----	----	-----	-----	-----

5.12.4 Start Parameter Message (,l' ,7')

Before starting a travel the lift controller transmit the desired travel distance and the allowed maximum lift speed to the drive controller. After calculating the optimal speed the drive controller answers with the minimum distance to travel and the needed deceleration distance regarding the calculated speed.

5.12.4.1 Start Parameter Message from Lift Controller

Before each travel the lift controller sends:

STX	1C	,l'	,7'	Vmax	Ss1	Ss2	Ss3	Ss4	Ss5	ETX
-----	----	-----	-----	------	-----	-----	-----	-----	-----	-----

Vmax maximum lift speed:
 ,1' = intermediate speed 1 (V3 DCP notation)
 ,2' = fast speed (V4 DCP notation)

Ss1...5 Desired distance in cm (ASCII coded in BCD format), distance to the provisional destination.
 (Ss1: 10⁴-digit; Ss2: 10³-digit; Ss3: 10²-digit; Ss4: 10¹-digit; Ss5: 10⁰-digit)

5.12.4.2 Response Parameter Message from Drive Controller

Response message from the drive controller after receiving lift controller's message:

STX	1C	,l'	,7'	ftyp	Sg1	Sg2	Sg3	Sg4	Sg5	Sv1	Sv2	Sv3	Sv4	Sv5	ETX
-----	----	-----	-----	------	-----	-----	-----	-----	-----	-----	-----	-----	-----	-----	-----

ftyp Type of travel (,s' = short travel, ,l' = long travel, with l (...long) the maximum lift speed is reached).

Sg1...5 Total distance in cm (ASCII coded in BCD format). If Ss > Sg, a long travel (l) is involved.
 (Sg1: 10⁴-digit; Sg2: 10³-digit; Sg3: 10²-digit; Sg4: 10¹-digit; Sg5: 10⁰-digit)

Sv1...5 Deceleration distance in cm (ASCII coded in BCD format). The remaining distance can be extended if it is longer than Sv.
 (Sv1: 10⁴-digit; Sv2: 10³-digit; Sv3: 10²-digit; Sv4: 10¹-digit; Sv5: 10⁰-digit)

5.12.5 Position Message (,l' ,9')

The actual position of the lift car will be send after each stopping⁽⁵⁾ from the lift controller to the drive controller. It will be the distance in mm between the actual position and the lowest floor level.

5.12.5.1 Position Message from Lift Controller

After each stop⁽⁵⁾, while the drive is stationary, the lift controller sends the position:

⁵ That also applies to travels using the speed assignments VI (inspection), V0 (crawling) or VN (relevelling).

STX	1C	,l'	,g'	SIGN	P1	P2	P3	P4	P5	P6	ETX
-----	----	-----	-----	------	----	----	----	----	----	----	-----

SIGN Sign / result ('E': invalid value, '+': positive value, '-': negative value)

P1...6 Position (value in mm from lowest floor level)

5.12.5.2 Response from Drive Controller

Response message from the drive controller after receiving lift controller's message:

STX	1C	,l'	,g'	ETX
-----	----	-----	-----	-----

6 Behaviour in Event of Transmission Errors

6.1 Lift Controller

- a) The lift controller has detected a checksum error in the reply message from the drive controller.
- b) Bit 7 (error in last message received) is set in the status byte of the reply message.

In both cases it is necessary to respond as follows:

The type of message (transmission of actual distance or desired distance) must be maintained (i.e. be the same as the previous message).

The actual values are transferred as commands.

In case a) bit 7 is to be set in the reply message.

In case b) the total change in distance since the last valid message cycle is to be transmitted as actual distance.

6.2 Drive Controller

- a) The drive controller has detected a checksum error in the message received from the lift controller. The drive controller ignores the message and sends a reply message with the following contents:

Status byte: contains the actual status of the drive controller with bit 7 (error in the last message received) set

Process data: contains the actual extended status respectively the actual deceleration distance (depending on the mode identification bit 15)

Communication bytes: each one should have the value 00 Hex

- b) In the message from the lift controller to the drive controller bit 7 (error in last reply message) is set in the command byte. The current commands are processed normally. The drive controller repeats the last send message to the lift controller.

Note:

If one of the both devices are detecting a checksum error in a message where also bit 7 (error in last message) is set, this bit must be ignored by the receiving device.

In the DCP4 mode the drive controller's use of remaining distance message simplifies the behaviour:

- The lift controller always sends the current command byte and the remaining distance.
- The drive controller always replies with the current status byte.
- In the event of transmission errors only the last communication byte sent is repeated.

7 Constrains

7.1 Interface

The RS485 standard is used as transmission level.

Transmission from the lift controller to the drive controller is serial and asynchronous

Baud rate: 38.400 Baud
 Data bits: 8
 Parity: none
 Stop bits: 1

7.2 Timing

Since a half duplex interface is involved, the corresponding driver must be switched over depending on direction. To avoid collisions the following timing has to be achieved:

Send driver switched off:	Maximum of 0,5 ms after the last bit sent
Maximum permissible time to respond to a lift controller message:	Maximum 10 ms after last bit received
Start of sending of lift controller message:	0,0000 ms
Latest time for switching off lift controller send driver / earliest time to start drive controller send:	2,0624 ms
Latest start of drive controller send:	11,5625 ms
Latest time for switching off drive controller send driver / earliest start for sending next lift controller message:	13,625 ms
Giving a transfer cycle of:	15 ms

The lift controller must ensure the distance is transmitted at least 30 ms before the corresponding deceleration point is finally reached. In other words the reply message from the drive controller, which tells the lift controller whether the new desired distance is accepted, must have arrived at the lift controller when the deceleration point is reached, even if the exchange of message has to be repeated because of a transmission error.

7.3 Timeout Safety Function

If, during the travel, 10 successive messages are received incorrectly or were completely lost (same as having 150 ms without communication), the drive controller switches to error.

If, while the drive controller is stationary, further 10 successive messages are received correctly without missing one, the operation is resumed.

At present the drive controller is stopped immediately a timeout error arises.

The response is therefore the same as for an interruption in the safety circuit.

There is no error message if the link is interrupted with the drive stationary!

Note:

To advance the safety it is recommend that the lift controller also checks if the messages are received correctly. In case of error it should act conveniently.

8 Definition of Travel Sequence

The following chapters introduce the principles of the travel sequences for the DCP3 and DCP4 modes.

8.1 Nomenclature

In the following chapters the DCP speed notation is used (see chapter 3.5.3.2).

The following abbreviations are used for the remaining distances and travel types.

SV1, SV2, SV3 resp. SV4	Fixed remaining distance for DCP3 travel with the speed V1, V2, V3 resp. V4
SV3' resp. SV4'	Maximum slowing down distance for DCP4 travel limited to V3 resp. V4
V3'-travel, V4'-travel resp. VN'-travel	Travel depending on remaining distance and limited to speed V3, V4 resp. VN

8.2 Diagrams

The diagrams used in the manual have the following form:

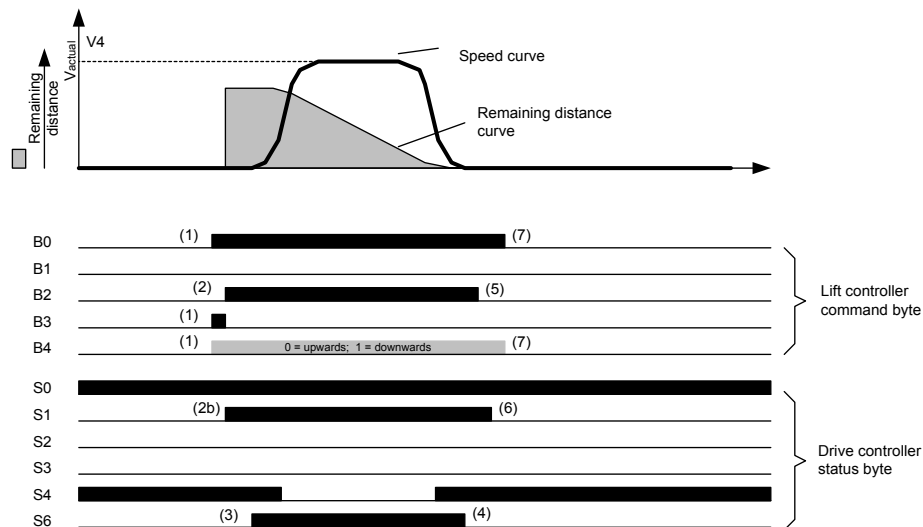

Figure 8-1: Form of Diagram

The bits B5, B6 and S5 aren't shown in the diagram because they aren't processed by the Kollmorgen lift controller program. Furthermore the bits B7 and S7 aren't displayed because they don't affect the travel sequence directly.

The numbers found in brackets are quoting the chronological order of setting and clearing the individual signals [(1) -> (2) -> (2b) -> (3) etc.]. The sequence (2b) can appear at the same time sequence (2) appears.

9 Features Common to DCP3 und DCP4

9.1 Notes on Command and Status Bits

The following notes be regarded equally to DCP3 and DCP4.

9.1.1 Command Bit B0: Drive Controller Enable

At the inspection mode or at the test control mode, the safety circuit is usually opened when the corresponding button is released.

-> Drive controller enable B0 must be switched off when the button is released.

At the inspection mode or at the test control mode, the drive controller enable B0 must be off when the drive is stationary.

Many lift controllers also treat relevering as a special travel. If the lift controller switches off the mechanical brake and motor contactors at the same time as the relevering speed, drive controller enable B0 is also to be switched off.

-> Drive controller enable B0 must be switched off if the safety circuit is interrupted.

9.1.2 Command Bit B4: Direction

The travel direction must be available throughout the travel. The drive decelerates immediately if the setting changes during the travel, but without the drive controller switching to fault.

9.1.3 Status Bit S0: Drive Controller Ready

The lift controller only starts a new travel if the *drive controller ready bit S0* is set.

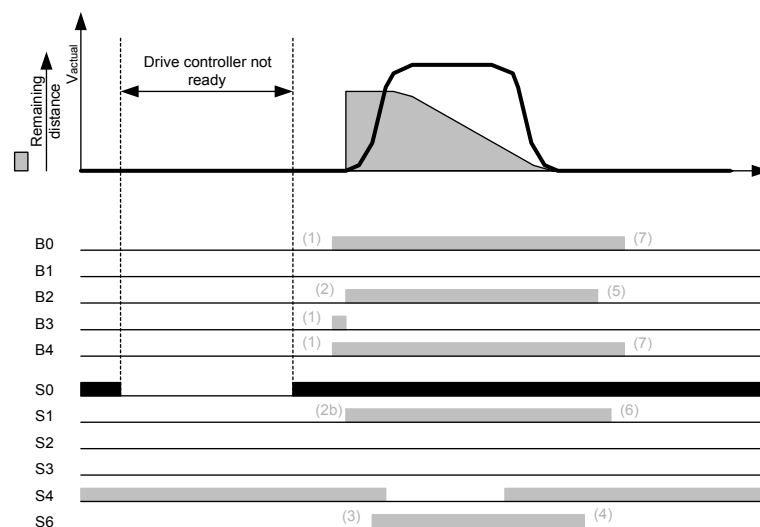

Figure 9-1: Drive Controller Ready Bit

9.1.4 Status Bit S1: Travel Activate Bit

- During normal operation the lift controller switches the motor contactors on while S1 = '1'.
- In case of a regular halt the drive controller should not set S1 from '1' to '0' before S6 is set to '0' and the lift controller has had time to close the mechanical brake.

9.1.5 Status Bit S2: Advance Warning

Notes:

- If re-starting is commenced despite this bit being set, an error message is sent to the drive controller.
- If advance warning S2 is activated during the travel (see diagram), the lift controller should no longer extend the remaining distance.
- The lift controller only starts a new travel if the *advance warning bit S2* is reset.

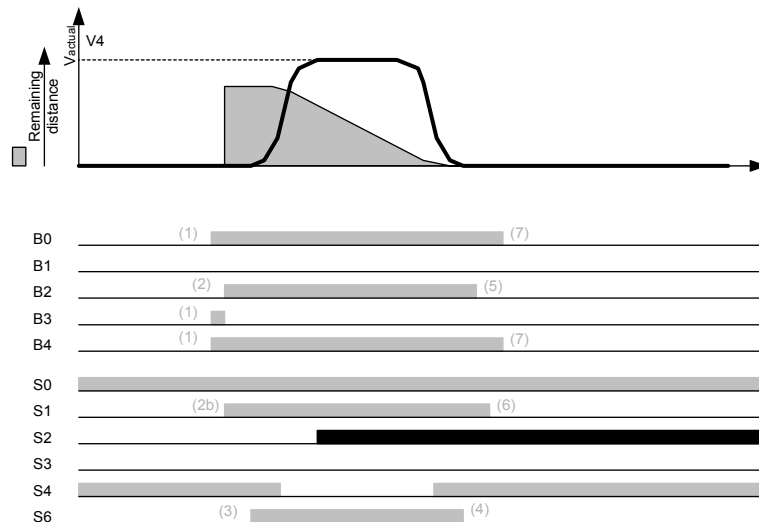

Figure 9-2: Advance Warning Bit

9.1.6 Status Bit S3: General Fault

Note:

- When *general fault bit S3* is activated, *drive controller enable bit B0* is to be reset.
- The lift controller must not start a new travel until *general fault bit S3* has been reset.

9.1.7 Status Bit S6: Mechanical Brake

Note:

- In case of a regular start the drive controller should set S6 from '0' to '1' when it has completed pre flux the motor.
- In case of a regular halt the drive controller should set S6 from '1' to '0' in the moment it has halted completely. In this situation the drive controller should hold the torque about 100ms, so that the lift controller can close the mechanical brake without the drive can freewheel.
- With S6, the lift controller must switch the mechanical brake without any delay.
- The lift controller has to monitor S6 or the MB relay, even during the travel.
- If *travel active bit S1* is not supervised and not evaluated, the motor contactors are to be switched off with a time delay after S6/MB is switched off!

9.2 Travels Independent of DCP3 and DCP4

9.2.1 Inspection Travel

9.2.1.1 Inspection Travel with VI

1. The speed mode "Inspection [bit G4]" (VI) is transmitted before the travel starts.
2. The travel starts with activation of *travel command bit B1* and *stop switch bit B2*.
3. When the lift levels at one of the end stops, the lift controller switches off *travel command bit B1* for starting the slowing down ramp. If the *stop switch bit B2* is still activated, the drive then continues to travel at crawl speed (V0).
4. Releasing the inspection button generally opens the safety circuit. An electrical stop is therefore not possible. When the inspection button is released the lift controller must switch off *drive controller enable bit B0*.

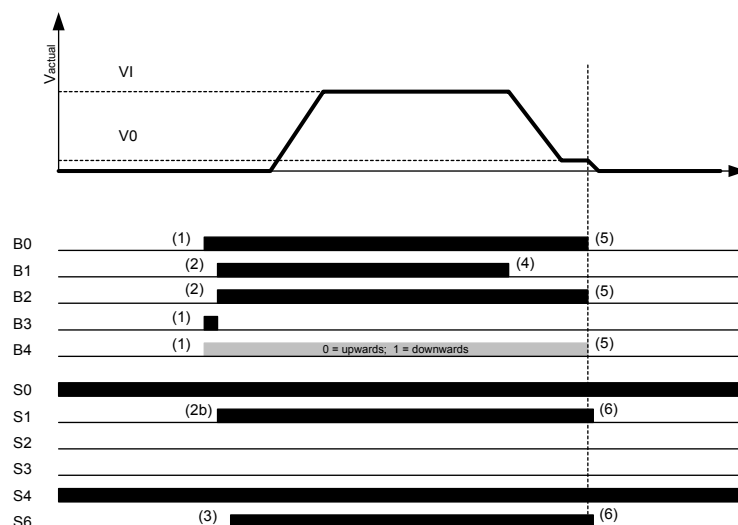

Figure 9-3: Inspection Travel

9.2.1.2 Inspection Travel with V0

In case the car is standing in the range of the end stops, an inspection travel towards the end may not start with the inspection speed (VI). In this case it must start with crawl speed (V0). This is realized by activating only stop switch bit B2 without activating travel command bit B1.

Note: Just like the inspection travel with VI the speed mode “Inspection [bit G4]” (VI) is transmitted before the travel starts!⁽⁶⁾

1. The speed mode “Inspection [bit G4]” (VI) is transmitted before the travel starts.
2. The travel starts with activation of *stop switch bit B2*.
3. During the time the *stop switch bit B2* is still activated, the drive then continues to travel at crawl speed (V0).
4. Releasing the inspection button generally opens the safety circuit. An electrical stop is therefore not possible. When the inspection button is released the lift controller must switch off *drive controller enable bit B0*.

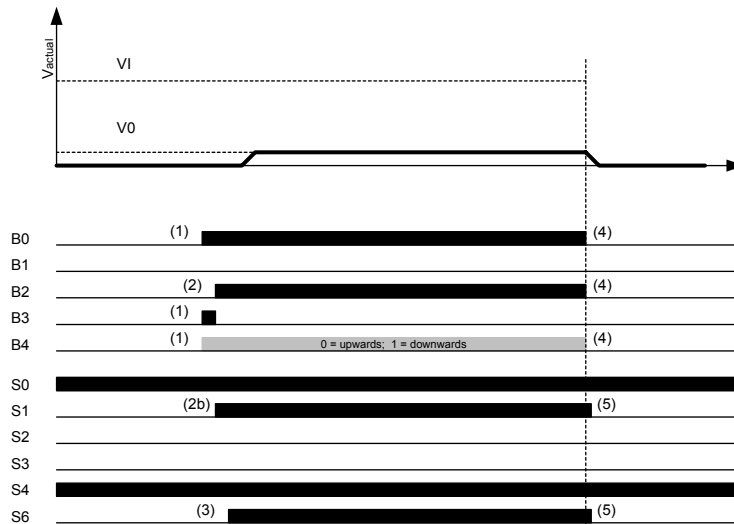

Figure 9-4: Inspection travel with V0

9.2.2 Test Control Travel

Test control travel and inspection travel works same.

⁶ This is necessary because some types of drive controllers in “DCP4 mode” can only realize an inspection travel with V0, if the “Speed mode” command is using the speed inspection bit G4 (VI).

9.2.3 Relevelling Travel none Depending on Remaining Distance

The relevelling travel none depending on remaining distance is used at DCP3 and in special cases at DCP4. At DCP4 relevelling travel depending on remaining distance is also applied (see chapter 11.1.4).

9.2.3.1 Relevelling Travel none Depending on Remaining Distance without *electric Stop*

Many lift controllers treat relevelling as a special case. The mechanical brake and the motor contactors are also switched off along with the relevelling speed (see step (3)).

1. Before the travel starts, the speed mode “Relevelling [bit G1]” (VN) is transmitted.
2. The travel starts with activation of *travel command bit B1*, but the stop switch is not set!
3. *Travel command bit B1* und *drive controller enable bit B0* are switched off at the same time.

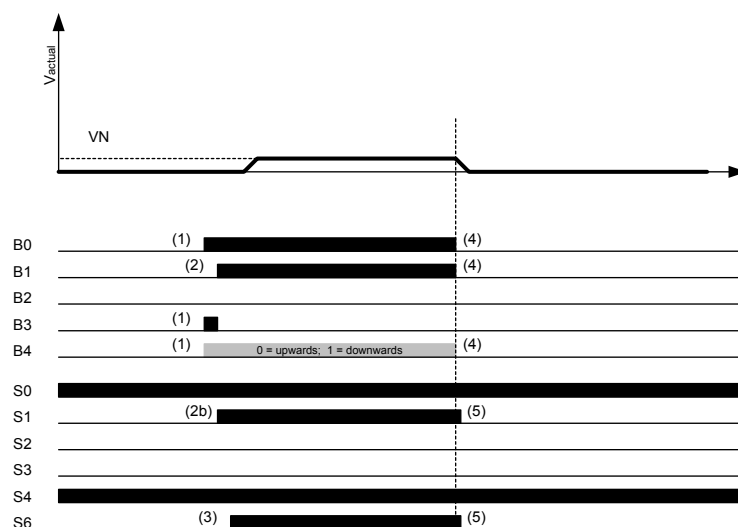

Figure 9-5: Relevelling Travel without electric Stop (DCP3)

CAUTION!:

- If the drive controller enable is not switched off, the motor contactors will be carrying current when opened.
- Since the motor is not being supplied with power during the time that elapses until the mechanical brake is applied, the drive can freewheel.

The method described in the next section is therefore of advantage.

9.2.3.2 Relevelling Travel none Depending on Remaining Distance with *electric Stop*

The following method allows smooth stopping:

1. Before the travel starts, the speed mode “Relevelling [bit G1]” (VN) is transmitted.
2. The travel starts with activation of *travel command bit B1*, but the stop switch is not set!
3. After the *travel command bit B1* has been switched off, *drive controller enable bit B0* remains activated. The drive decelerates to 0 and holds until the mechanical brake is applied.
4. *Drive controller enabled bit B0* and the motor contactors are not switched off until the *mechanical brake bit S6* and *travel activated bit S1* bits are switched off.

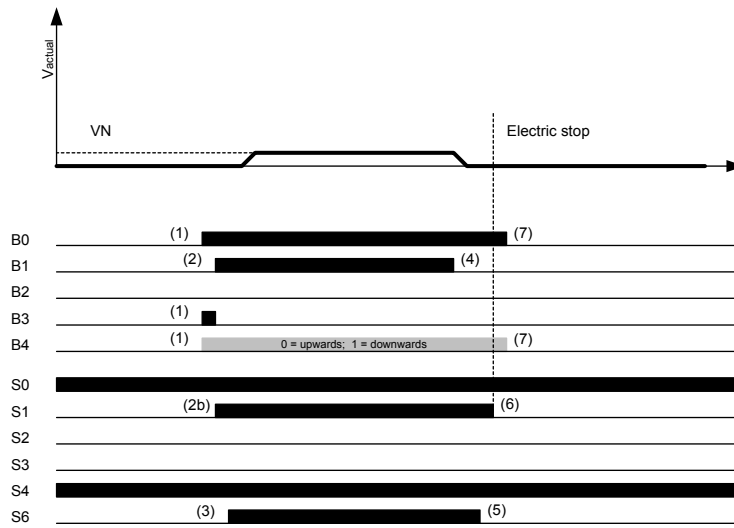

Figure 9-6: Relevelling Travel with electric Stop (DCP3)

10 DCP3: Lift Controller without Absolute Sensor System

10.1 Travels at V4 followed by Constant Deceleration Distance SV4

10.1.1 Long Travel at high Lift Speed V4

1. Before the travel starts, the speed mode "Fast [bit G7]" (V4) is transmitted.
2. The travel starts with activation of *travel command bit B1*.
3. After the travel command has been switched off, the drive decelerates to crawl speed within the fixed distance (SV4). The distance is supplied by the motor's incremental encoder. *Stop switch bit B2* must be activated no later than this point in time.
4. The lift controller positions the lift car with the *stop switch bit B2*.
5. The lift controller switches the travel contactors off when the drive controller ends the travel at S1 = 0.

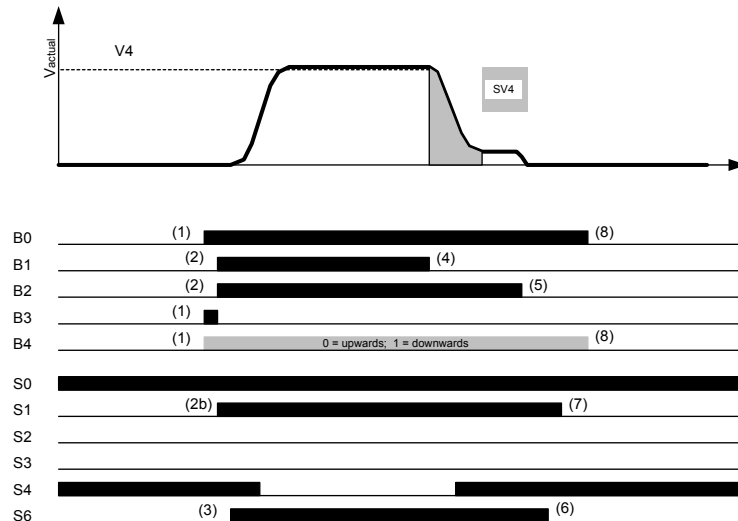

Figure 10-1: V4 long Travel (DCP3)

10.1.2 Time Optimised short Travel at Lift Speed V4

1. Before the travel starts, the speed mode “Fast [bit G7]” (V4) is transmitted.
2. The travel starts with activation of *travel command bit B1*.
3. By contrast with the above sequence, *travel command bit B1* is switch off before the fast speed (V4) is reached. The same fixed remaining distance (SV4) as for the long travel is covered in slowing to crawl speed (V0).

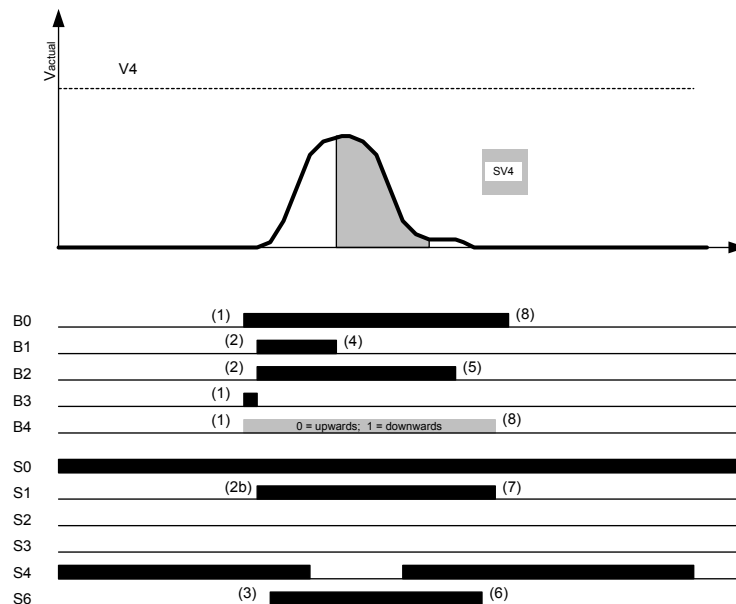

Figure 10-2: V4 short Travel (DCP3)

10.2 Travels at intermediate speed V3, V2 and V1

10.2.1 Long Travel at intermediate speed

It's the same procedure like chapter 10.1.1 with fast speed with the distinguish, that in step (1) the appropriate intermediate speed must be transmitted. The deceleration distance is dependent on the selected speed.

V3 (intermediate 1 [Bit G6])	->	SV3
V2 (intermediate 2 [Bit G5])	->	SV2
V1 (intermediate 3 [Bit G3])	->	SV1

10.2.2 Time optimised short Travel at intermediate speed

It's the same procedure like chapter 10.1.2 with fast speed with the distinguish, that in step (1) the appropriate intermediate speed must be transmitted⁽⁷⁾.

10.3 Crawl Travel in DCP3

1. Before the travel starts, the speed mode "Crawl [bit G0]" (V0) is transmitted.
2. The travel starts with activating of *travel command bit B1* and the *stop switch bit B2*.
3. After *travel command bit B1* and the *stop switch bit B2* have been withdrawn, the drive carries out positioning.
4. *Drive controller enable bit B0* must not be switched off until the *mechanical brake bit S6* and the *motor contactors bit S1* have been switched off.

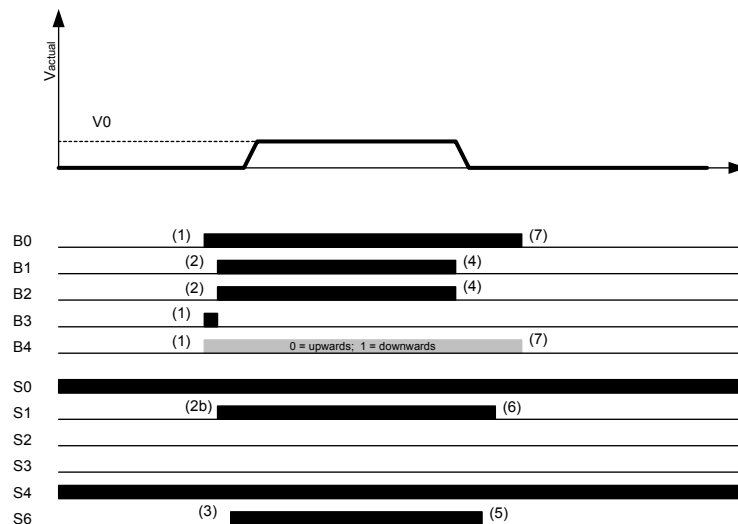

Figure 10-3: Crawl Travel (DCP3)

Note:

The lift can also be run without *travel command bit B1*. For travels with *stop switch bit B2* only, the speed selection is automatically set to crawling speed V0.

⁷ Note: Fixed remaining distances SV1 and SV2 for short travels aren't supported by all manufacturers of drive controllers.

11 DCP4: Lift Controller with Absolute Sensor System

At DCP4 travels are normally carried out time optimised and depended on remaining distance. Furthermore travels with none depending on remaining distance as described at chapter 10 are supported here, so that special kind of travels can be realized, e.g. learning travel for the absolute sensor system.

11.1 Time Optimised Direct Levelling Depending on Remaining Distance

11.1.1 Definition and Features of V4', V3' and VN' Travels

With time optimised travels depending on remaining distance there are no points at which lift speeds are switched off. Depending on the distance to be travelled, the corresponding maximum speed V4, V3 or VN may not be reached during the travel. Instead, the optimum speed for reaching the destination is determined. The lift travels to the destination at this speed. To clearly distinguish them from DCP3 travels, the DCP4 mode travels are therefore identified with an apostrophe (') (see chapter 8.1).

The travels described below have the following common features:

- a) Before the travel starts a preselected speed is transmitted. This is just a limit that the drive controller is not allowed to exceed. The actual value of the speed is decided by the drive controller itself, by calculation the time optimised travel curve from the actual remaining distance.
- b) The travels depending on remaining distance are made without *travel command bit B1*.
- c) Up from starting the travel, the absolute remaining distance can be read by using DCP.
- d) *Stop switch bit B2* remains activated until the lift car comes to the level and the drive controller switches the *mechanical brake bit S6/MB* off.

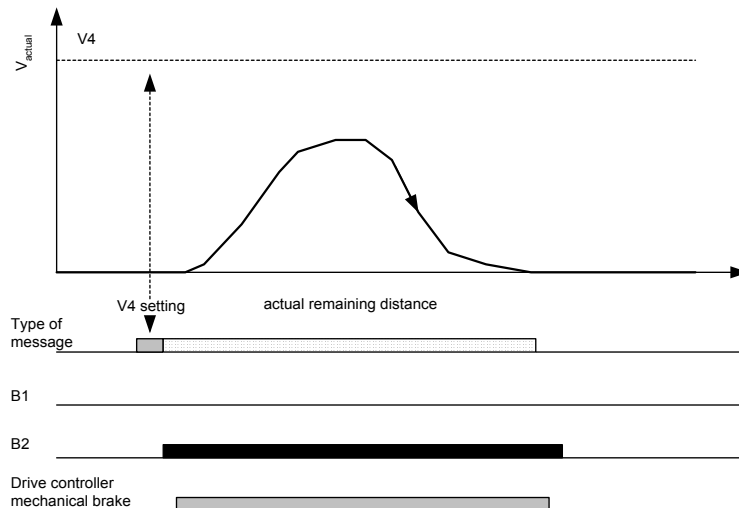

Figure 11-1: Travel Depending on Remaining Distance (DCP4)

11.1.2 V4'-Travel

1. Before the travel starts, the speed mode "Fast [bit G7]" (V4) is transmitted.
2. The travel starts with activation the *stop switch bit B2*. After starting the travel, the absolute remaining distance can be read by using DCP.
3. The drive decelerates until the lift car comes to the level, without adopting crawl speed. The drive controller then switches the *mechanical brake bit S6* (or using MB) off.
4. The controller does not withdraw the *stop switch bit B2* until *mechanical brake bit S6/MB* is switched off. The maximum deceleration distance is SV4'.

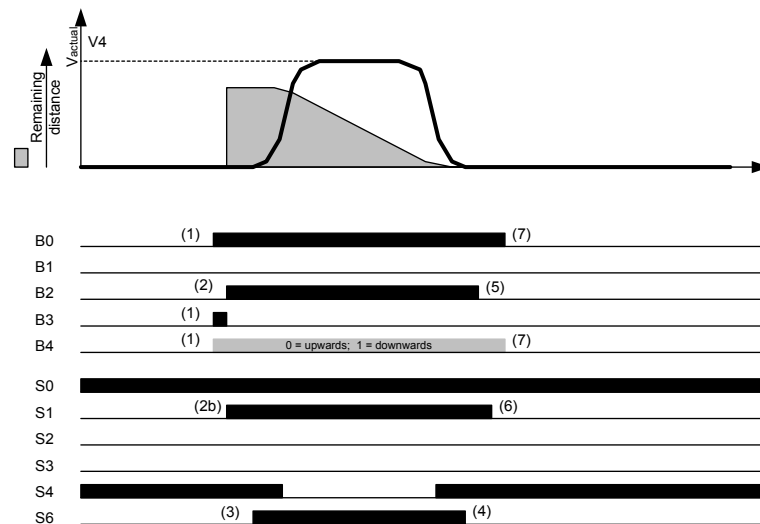

Figure 11-2: V4' long Travel (DCP4)

Note:

The controller can increase the remaining distance while it is greater than the deceleration distance the drive controller had transmitted before the beginning of the travel (see chapter 11.1.2.1).

Special case: Advantage of DCP4 with time optimised travel depending on remaining distance:

If, at the start of the travel, a remaining distance is set to short, so that the speed V4 isn't possible to reach, the drive controller calculates a time optimised lift travel curve online.

The initial remaining distance can be very much shorter than the maximum deceleration distance SV4' required.

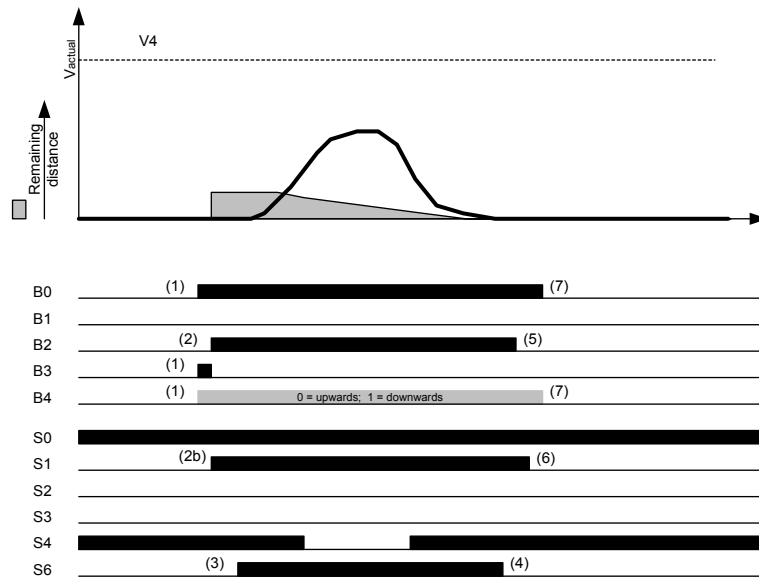

Figure 11-3: V4' short Travel (DCP4)

Examples:

1. If a travel has been interrupted during deceleration (e.g. emergency stop is active), the trip can only be continued to the next level with crawl speed. If the point at which fast speed was switched off was 1.20m before the lift car comes to the level, and the emergency stop was activated 1.00m before this level, subsequent travel at the crawl speed of 5cm/s lasts around 20 second.

In this case: With an initial remaining distance setting of 1.00m and selection of speed V4, the drive controller now calculates the new time optimised travel curve.

2. Any number of short travels with different level distance can be achieved with optimised timing with just one speed setting.

Safety note:

If the remaining distance at the start of travel is less than 20cm, the drive controller automatically limits the maximum speed to crawl (V0).

11.1.2.1 Exchange of Parameters between Lift Controller and Drive Controller before the Travel

To enable the lift controller to track the floor level reached correctly, and know which calls it can still travel to during travel, it requires additional information from the drive controller. Before the start, the drive controller is therefore told on the communication channel how far the lift is to travel. It responds on the same channel with details of the minimum distance the lift has to travel at the calculated speed, and how long the remaining distance has to stay to enable it to be extended.

The messages have the following structure.

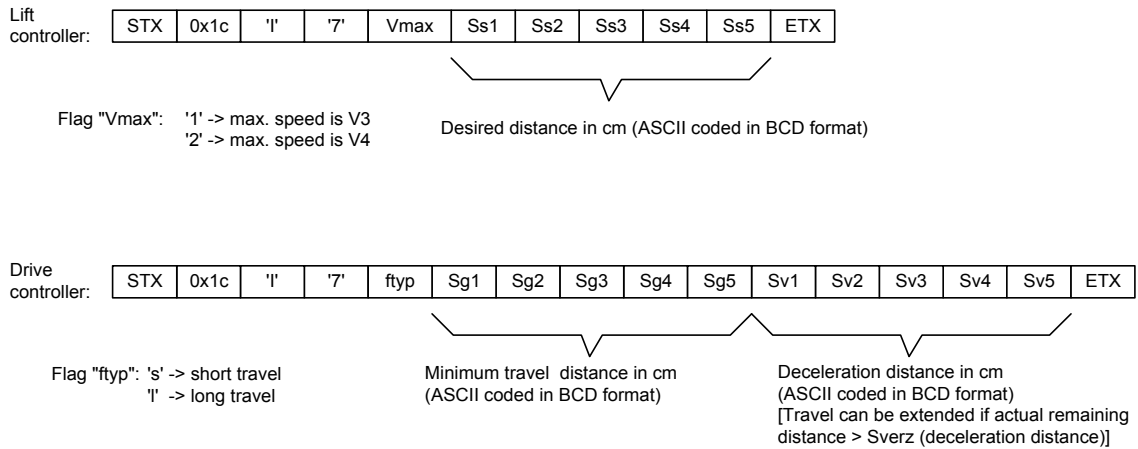

Example1: Short distance travel:

The controller should travel to a floor 3.0 metres away. The maximum permissible lift speed is V4 .

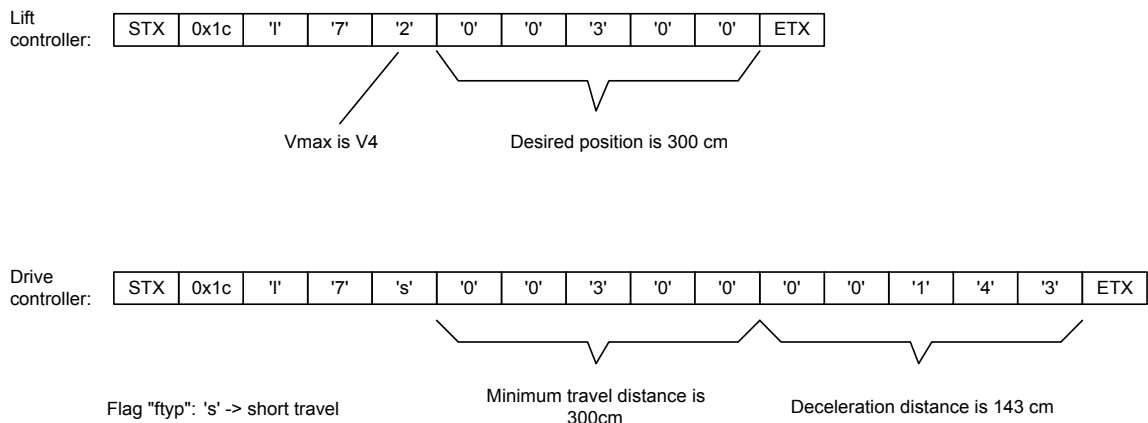

The drive controller responds with the information that the travel is a short distance run, that, at the calculated lift speed, it has to cover a distance of at least 3.00m, and that the decelerating distance is 1.43m.

The following figure shows the meaning of the distances Ss, Sg and Sv for a short distance travel.

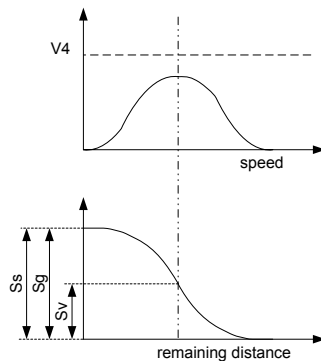
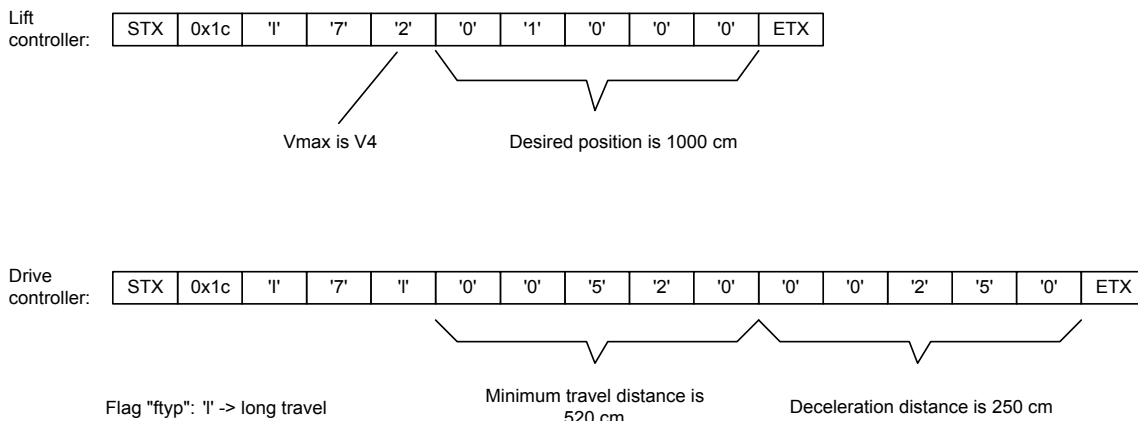

Figure 11-4: short travel

Example2: Long distance travel:

The controller should travel to a floor 10.0 metres away. The maximum permissible lift speed is V4 .



The drive controller responds with the information that, at the calculated lift speed, it has to cover a distance of at least 5.20m, and that an increase in the remaining distance can only be accepted if the residual value is not less then 2.50m. Calls on floors more than 5.20m from the starting point can therefore be accepted while the actual remaining distance is greater than 2.50m.

The following figure shows the meaning of the distances S_s, S_g and S_v for a long distance travel.

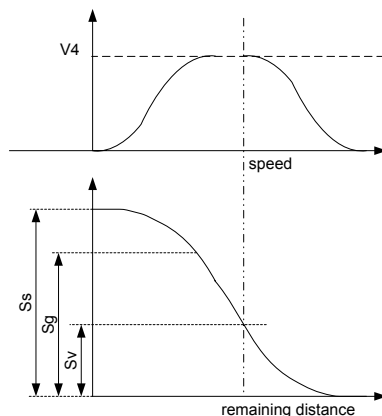

Figure 11-5: long travel

11.1.3 V3'-Travel

Same procedure as described at chapter 11.1.2.

Difference: The speed mode "Intermediate 1 [bit G6]" (V3) is transmitted. This limits the speed to V3.

Application: On short travels as well, the lift can be operated with preselection of speed V4 as described above. Only in cases which it is desirable to limit the speed is it then possible to work with V3.

11.1.4 VN'- Relevelling Travel Depending on Remaining Distance

The usual method of relevelling is often just a compromise. With *DCP4*, however, stipulation of the remaining distance makes relevelling accurate to the millimetre possible.

1. Before the travel starts, the speed mode "Relevelling [bit G1]" (VN) is transmitted.
2. The travel starts with activation of *stop switch bit B2*. From the start of the travel the absolute remaining distance is read in by DCP.
3. The drive decelerates depending on the remaining distance until the lift car comes level.
4. The lift controller does not withdraw *stop switch bit B2* until the *mechanical brake bit S6/MB* is switched off.
5. The lift controller must not switch off the *drive controller enable bit B0* until the end of the travel $S1=0$.

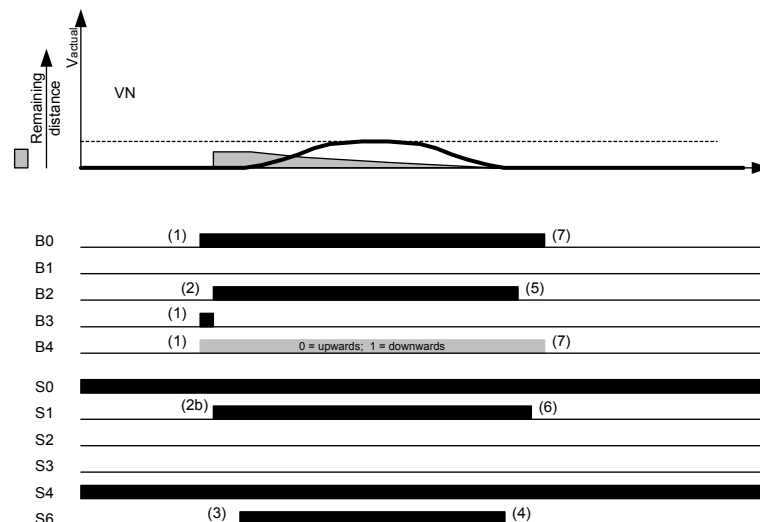

Figure 11-6: VN' Relevelling Travel (DCP4)

11.2 Crawl Travel in *DCP4*

There is no definition of a crawl travel sequence in *DCP4*. The lift controller chooses one of the described travel sequences depending on the remaining distance.

Exception:

- If the remaining distance at the start is less than 20cm, the drive controller limits the maximum speed to crawl.
- The inspection and test control travel are independent of the *DCP3* and *DCP4* modes. In this case the speed is limited to crawl when the lift levels at the end stop.

12 Fast Start Function

The 'fast start function' allows to magnetise the motor already when the doors are closing and holding the lift car with open brake in the level position. This function can be used with DCP3 and DCP4. If the 'fast start function' is active and the doors are completely closed the car can immediately start to move, without losing time for magnetising the motor and opening the brakes.

Attention:

Please note that some additional wirings and shaft signals are necessary to meet the requirements of the EN81-1.

12.1 Starting sequence

The following two figures are showing the starting sequences for DCP3 and DCP4.

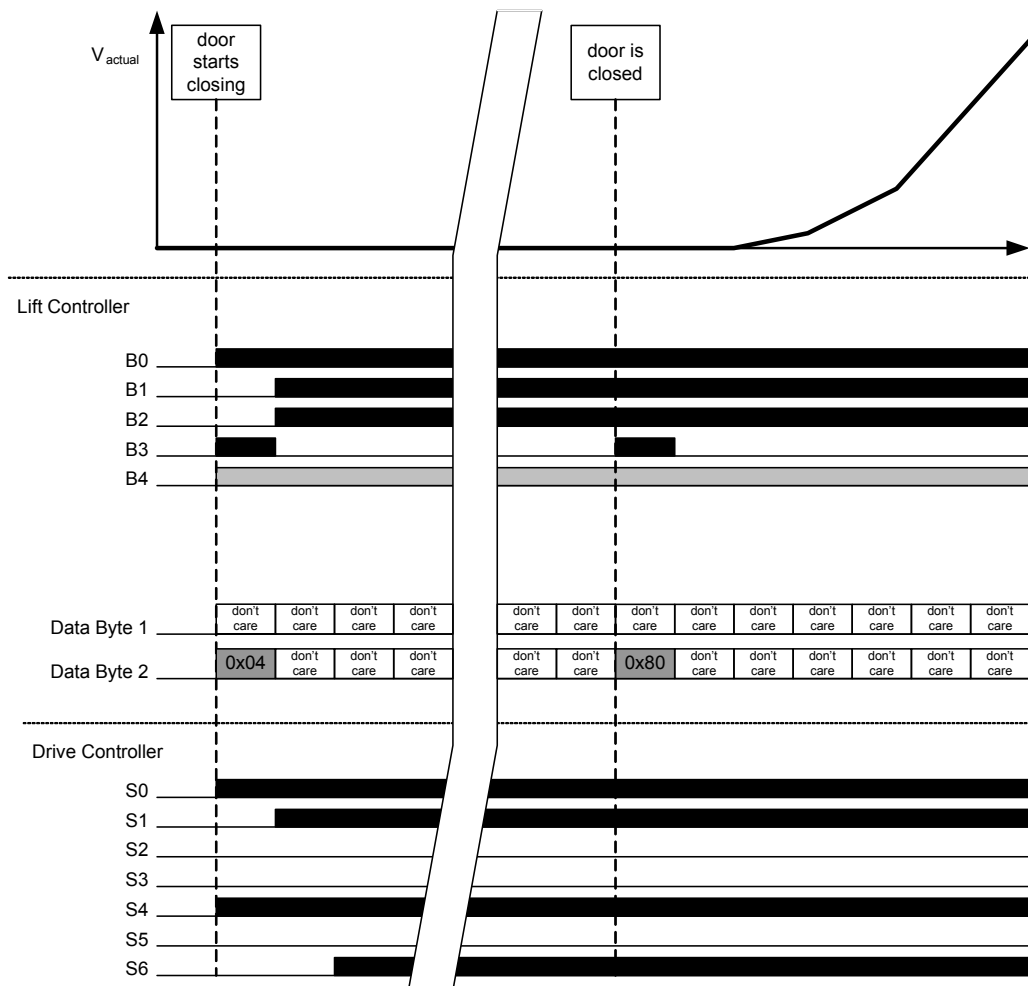

DCP3: Starting sequence 'fast start function'

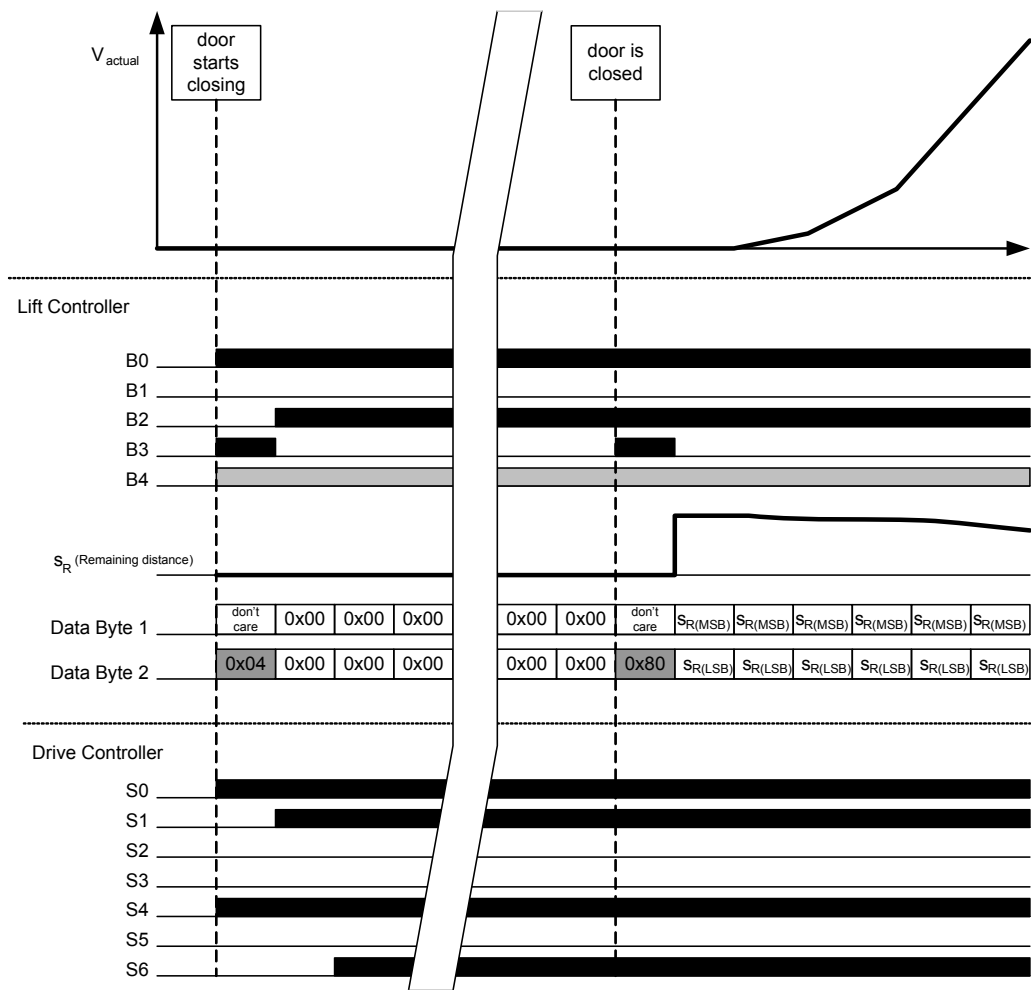

DCP4: Starting sequence 'fast start function'

12.1.1 Activation of the 'fast start function'

The 'fast start function' will be activated, if the travel sequence starts with a speed message (B3=1, B2=0, B1=0, B0=1) using the speed mode VF (0x04) in the lift controller's 'data byte 2'.

12.1.2 Actions and controls during 'fast start function'

If the 'fast start function' is active, the lift car will be actively held in the position with open brakes by the drive controller.

If DCP4 is used and the 'fast start function' is active, the lift controller must set the remaining distance to the value '0x0000' during this time period.

The time during 'fast start function' is active should be limited and monitored on both controllers (lift controller and drive controller).

If the doors are reversing, the 'fast start function' should be cancelled with a stop sequence.

12.1.3 Transition from 'fast start function' to normal travel

An additional speed message (DCP3: B3=1, B2=1, B1=1, B0=1; DCP4: B3=1, B2=1, B1=0, B0=1) with a regular speed mode in the lift controller's 'data byte 2' terminates the 'fast start function' and initiates the normal travel with the selected speed.

12.2 Premature termination of the 'fast start function'

There are some situations where it is necessary to abort the 'fast start function'.

Examples for these situations are:

- The doors are reversing (opening again).
- Timeout monitor occurs (e. g. the doors can't be closed because they are blocked).
- A fault occurs (e. g. motor thermistor or leaving the door zone).

In principle there are two ways the 'fast start function' can be aborted:

- Immediate termination regardless to the state of the drive controller's status bit S6 'mechanical brake'
- Premature termination considering the state of the drive controller's status bit S6 'mechanical brake'

12.2.1 Immediate termination regardless to the state of S6 'mechanical brake'

The 'fast start function' can be terminated immediately by clearing the lift controller's command byte.

Attention:

A termination of the 'fast start function' regardless to the state of the drive controller's status bit S6 'mechanical brake' can cause a drifting car and a disconnection of the main contactors under load. Therefore, whenever possible termination considering the state of the drive controller's status bit S6 'mechanical brake' (see chapter 12.2.2) should be preferred.

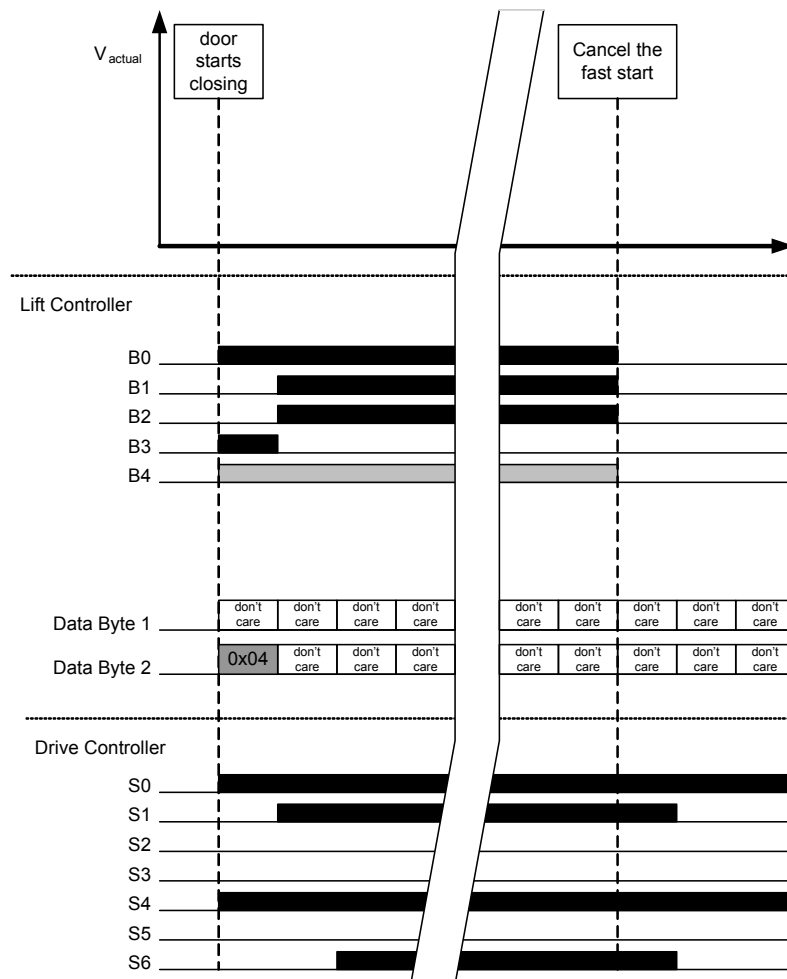

DCP3: Immediate termination

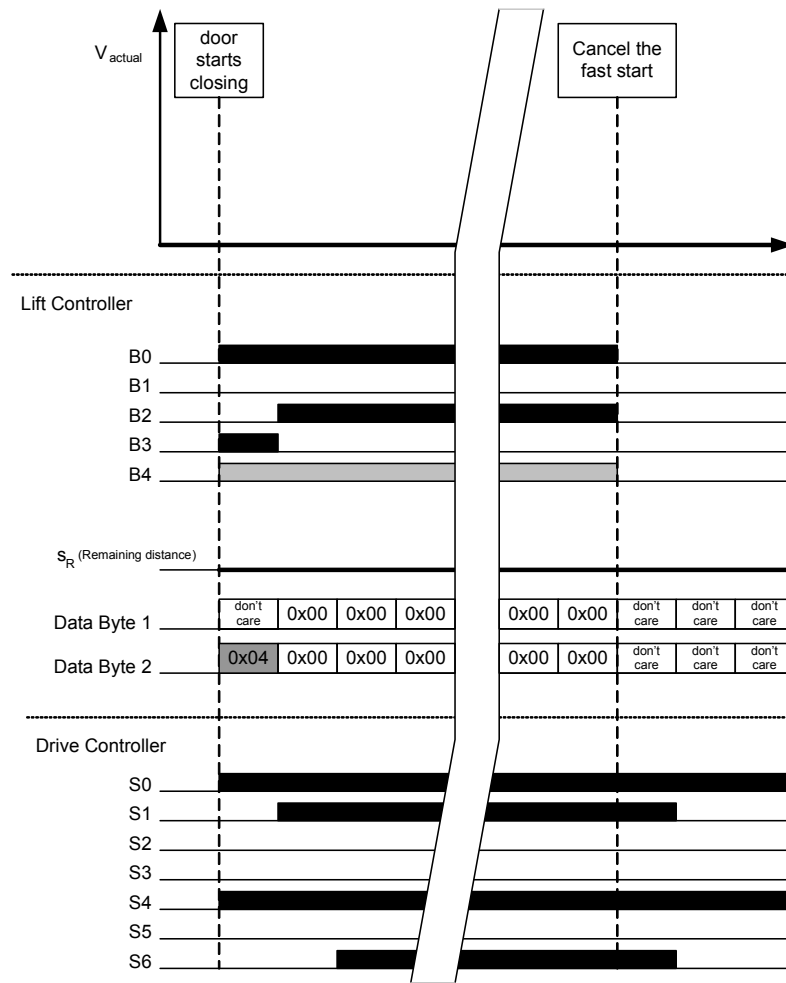

DCP4: Immediate termination

12.2.2 Premature termination considering the state of S6 'mechanical brake'

The controlled premature termination of the 'fast start function' is initiated by a stopping message (B2=0, B1=0, B0=1). This will cause the drive controller immediately to close the brakes. After completing the brake sequence and de-magnetising the motor, the drive controller or lift controller will open the main contactors.

Whenever possible the lift controller should use this method for premature termination, because it prevents the car from drifting and the main contactors from disconnection under load.

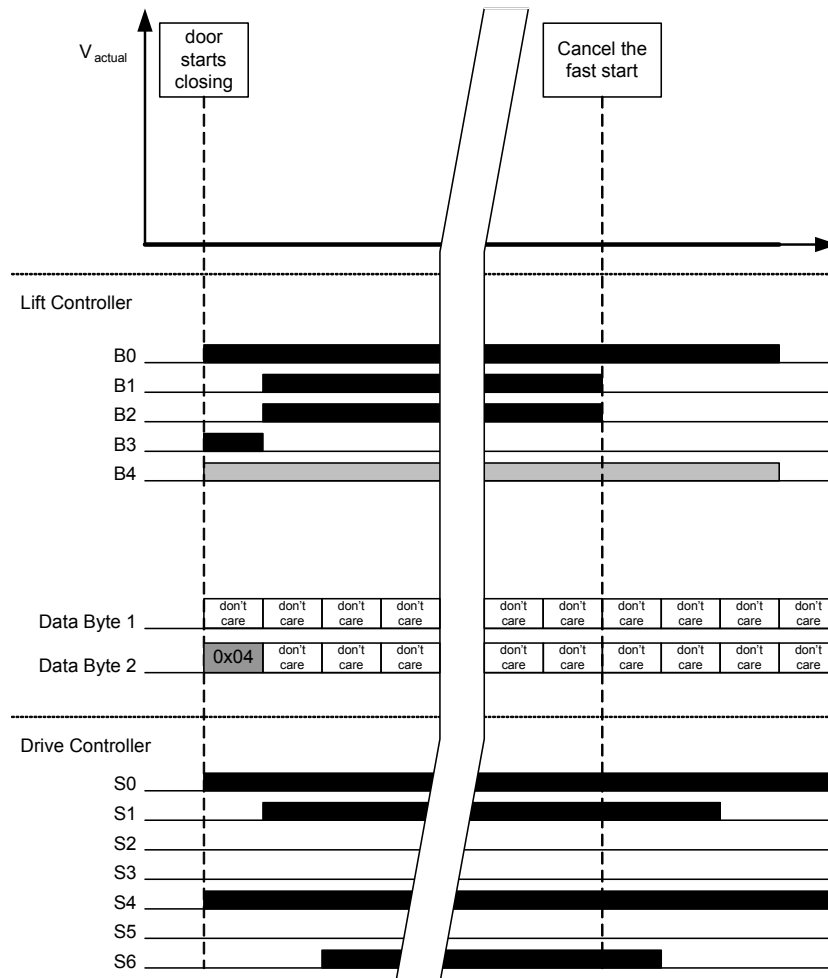

DCP3: premature termination

13 Appendix A: Character set of the communication data channel

!	0x21	→	0x7E	A	0x41	a	0x61	α	0xE0
„	0x22	←	0x7F	B	0x42	b	0x62	β	0xE2
#	0x23	≡	0xB0	C	0x43	c	0x63	ε	0xE3
\$	0x24	°	0xDF	D	0x44	d	0x64	μ	0xE4
%	0x25	±	0xF1	E	0x45	e	0x65	σ	0xE5
&	0x26	∞	0xF3	F	0x46	f	0x66	ρ	0xE6
'	0x27	√	0xE8	G	0x47	g	0x67	π	0xF7
(0x28	÷	0xFD	H	0x48	h	0x68		
)	0x29			I	0x49	i	0x69	Ρ	0xF0
*	0x2A			J	0x4A	j	0x6A	Θ	0xF2
+	0x2B	0	0x30	K	0x4B	k	0x6B	Ω	0xF4
,	0x2C	1	0x31	L	0x4C	l	0x6C	Σ	0xF6
-	0x2D	2	0x32	M	0x4D	m	0x6D		
.	0x2E	3	0x33	N	0x4E	n	0x6E		
/	0x2F	4	0x34	O	0x4F	o	0x6F		
:	0x3A	5	0x35	P	0x50	p	0x70		
;	0x3B	6	0x36	Q	0x51	q	0x71		
<	0x3C	7	0x37	R	0x52	r	0x72		
=	0x3D	8	0x38	S	0x53	s	0x73		
>	0x3E	9	0x39	T	0x54	t	0x74		
?	0x3F			U	0x55	u	0x75		
@	0x40			V	0x56	v	0x76		
[0x5B			W	0x57	w	0x77		
¥	0x5C			X	0x58	x	0x78		
]	0x5D			Y	0x59	y	0x79		
^	0x5E			Z	0x5A	z	0x7A		
_	0x5F								
`	0x60					ä	0x84		
{	0x7B					ö	0x94		
	0x7C					ü	0x81		
}	0x7D					ß	0xE1		

14 Appendix B: Summary

Master Message (lift controller)						
byte1	byte2	byte3	byte4	byte5	byte6	
command byte	data byte 1	data byte 2	comm. byte 1	comm. byte 2	checksum	
B7 error in last reply message distance (0: actual 1: desired)	B6 speed change	B5 travel direction (0=up, 1=down)	B4 speed mode	B3 V0 off switch	B2 travel command (only in DCP3)	B1 drive controller enable remaining distance MSB (only DCP4)
command byte B8 = "0": remaining distance LSB (only DCP4)		command byte B8 = "1": speed mode		expanded data communication		
remote keypad control		expanded data communication		remote keypad control		
the checksum is the result of an XOR operation of the bytes bytet1, bytet2, bytet3, bytet4 and bytet5						

Slave Message (drive controller)						
byte1	byte2	byte3	byte4	byte5	byte6	
status byte	data byte 1	data byte 2	comm. byte 1	comm. byte 2	checksum	
S7 error in last message received	S8 open mechanical brake	S5 desired distance/speed accepted	S4 0, V >= 0.3m/s; 1, V < 0.3m/s	S3 general fault active	S2 advance warning active	S1 travel active
S0 drive controller ready	D15 0	deceleration distance		expanded data communication		
D14 not used	D13 not used	D12 not used	D11 not used	D10 recommended direction	D9 reduced in term.circ.-volt	
D8 reserved	D7 reserved	D6 reserved	D5 reserved	D4 reserved	D3 reserved	
D2 over speed (0: >=; 1: <)	D1 bord. speed (0: >=; 1: <)	expanded data communication		remote display control		
expanded data communication		remote display control		expanded data communication		
remote display control		expanded data communication		remote display control		
the checksum is the result of an XOR operation of the bytes bytet1, bytet2, bytet3, bytet4 and bytet5						

speed modes (encoded in data byte 2, when bit B3 is set in the command byte)							
0x80	0x40	0x20	0x10	0x08	0x04	0x02	0x01
V4	V3	V2	V1	V1	VF	VN	V0
fast	intermediate 1	intermediate 2	inspection	intermediate 3	fast start	retlevelling	crawl

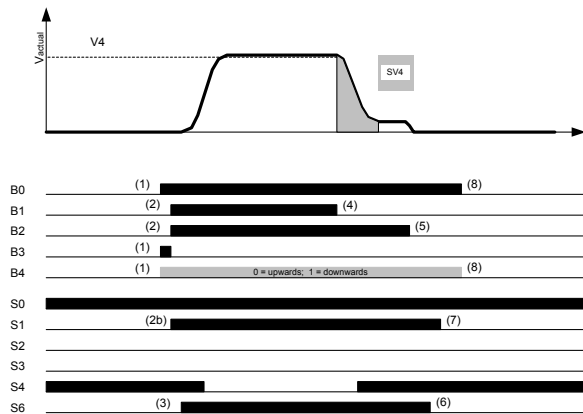

V4 long Travel (DCP3)

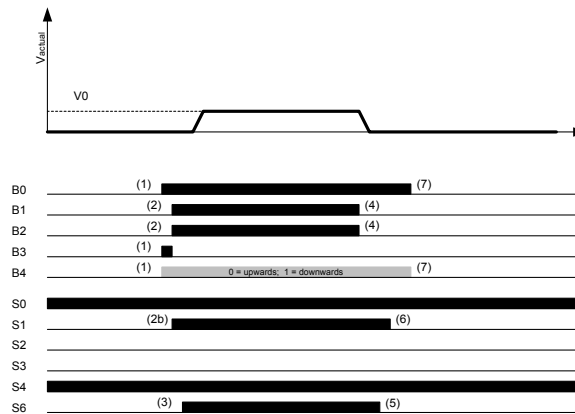

Crawl Travel (DCP 3)

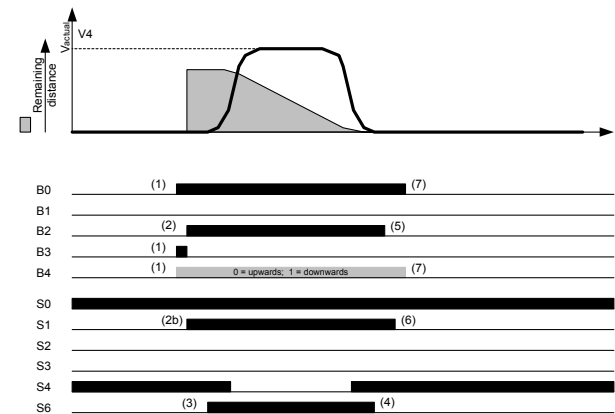

V4' long Travel (DCP4)

Notes:

- 1) The DCP notation is used for all speeds.
- 2) The numbers found in brackets are quoting the chronological order of setting and clearing the individual signals [(1) -> (2) -> (2b) -> (3) etc.].
- 3) (2b) can appear at the same time (2) is appearing.

Specification

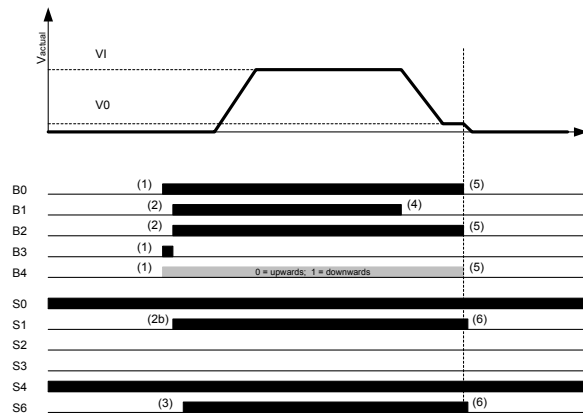

Inspection Travel using VI (DCP3 and DCP4)

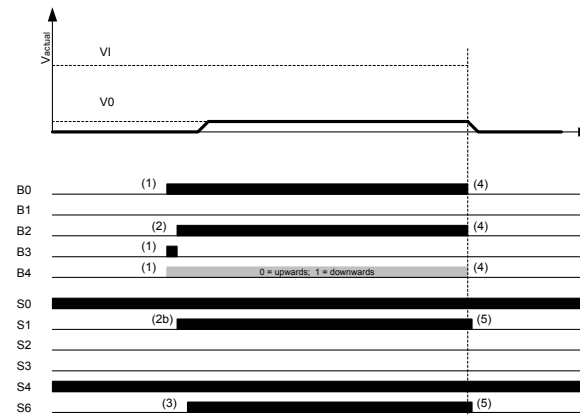

Inspection Travel using V0 (DCP3 and DCP4)

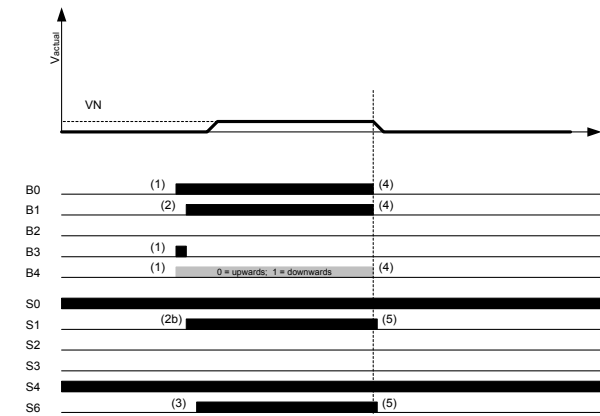

Relevelling Travel without electric Stop (DCP3)

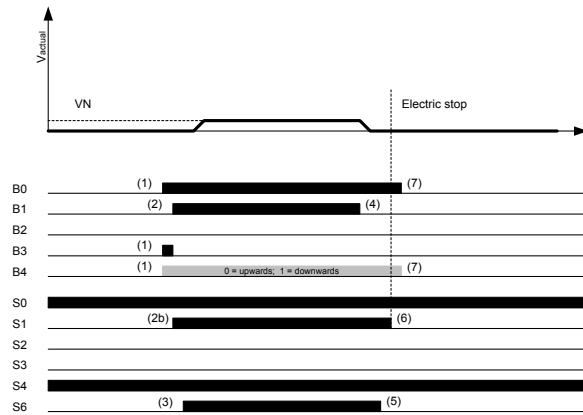

Relevelling Travel with electric Stop (DCP3)

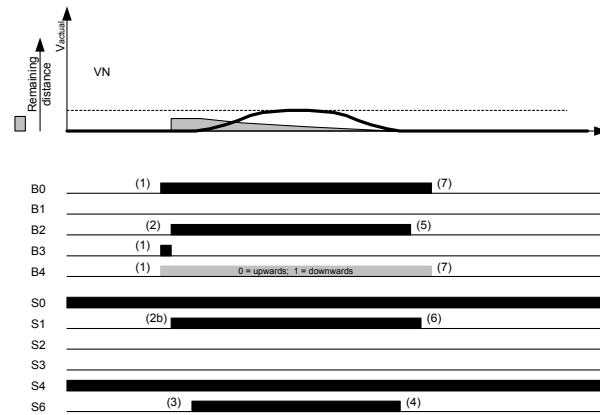

VN' Relevelling Travel (DCP4)